

WiFi Meets ML: A Survey on Improving IEEE 802.11 Performance with Machine Learning

Szymon Szott, Katarzyna Kosek-Szott, Piotr Gawłowicz, *IEEE Student Member*, Jorge Torres Gómez, *IEEE Member*, Boris Bellalta, *IEEE Senior Member*, Anatolij Zubow, *IEEE Senior Member*, Falko Dressler, *IEEE Fellow*

Abstract—Wireless local area networks (WLANs) empowered by IEEE 802.11 (WiFi) hold a dominant position in providing Internet access thanks to their freedom of deployment and configuration as well as affordable and highly interoperable devices. The WiFi community is currently deploying WiFi 6 and developing WiFi 7, which will bring higher data rates, better multi-user and multi-AP support, and, most importantly, improved configuration flexibility. These technical innovations, including the plethora of configuration parameters, are making next-generation WLANs exceedingly complex as the dependencies between parameters and their joint optimization usually have a non-linear impact on network performance. The complexity is further increased in the case of dense deployments and coexistence in shared bands. While classic optimization approaches fail in such conditions, machine learning (ML) is well known for being able to handle complexity. Much research has been published on using ML to improve WiFi performance and solutions are slowly being adopted in existing deployments. In this survey, we adopt a structured approach to describing the various areas where WiFi can be enhanced using ML. To this end, we analyze over 200 papers in the field providing readers with an overview of the main trends. Based on this review, we identify both open challenges in each WiFi performance area as well as general future research directions.

Index Terms—WiFi, WLAN, IEEE 802.11, Wireless LAN, Machine Learning, Deep Learning, Neural Networks.

I. INTRODUCTION

Wireless local area networks (WLANs), standardized in IEEE 802.11 and commercialized as WiFi, hold a dominant position in providing wireless Internet access. According to Cisco’s Visual Networking Index Forecast, WiFi’s share of Internet traffic will increase to 51% by 2022 [1]. Today, WiFi 6 [2]–[4] has become state of the art for all new consumer products and WiFi 7 [5]–[7] is already under development. There are several reasons for the popularity of WiFi: well-defined use cases, freedom of deployment and configuration

(thanks to operating in unlicensed bands), as well as inexpensive in manufacturing and highly interoperable devices.

The 802.11 protocol family has received, in recent years, regular updates leading to performance improvements and new features. These technical innovations provide a challenge: *the next-generations of WiFi are becoming exceedingly complex*. Specifically, each new mechanism, designed to improve network performance, comes with a plethora of parameters which have to be configured. Additionally, there are new application requirements: WiFi is no longer limited to broadband Internet access, but is also being used in other situations, e.g., ultra-low latency communication for machine-to-machine communication. This multi-modal operation needs to be supported through proper configuration, which in most cases is left out of the standard. For example, depending on the combination of resource unit (RU) assignment in 802.11ax, the network throughput may vary by more than 100% (i.e., between 100 and 280 Mb/s in the scenario considered in [2]). In most cases, multiple parameters have to be jointly optimized, which is a non-trivial task as the dependencies between parameters and their joint optimization have a highly non-linear impact on network performance. For example, [8] shows that the performance of overlapping 802.11 WiFi networks is not linear with the sensitivity and the transmission power. The level of complexity is further increased in the case of coexisting networks, where diverse parameters have to be set across multiple nodes with a multi-modal operation in mind (i.e., with different applications having different quality of service (QoS) requirements).

Up till now, the goal of the mainline 802.11 amendments was to provide high throughput (802.11n, 802.11ac) and efficiency in dense environments through deterministic channel access (802.11ax). However, future WiFi generations are anticipated to accommodate also ultra-low latency and ultra-high reliability traffic (802.11be). Hence, the proper and timely update of the transmission settings for each class of traffic is of key importance. Meanwhile, *finding adequate or even, in the best case, optimal configurations in an enormous search space using traditional algorithms is too time and computation resource consuming*, i.e., by the time the proper configuration is found, it is already out-dated as the propagation characteristics have changed. Additionally, new WLAN mechanisms also bring overhead in terms of additional measurements which provide input to their respective control algorithms. In the past, with only a few possible modulation and coding scheme (MCS) values (i.e., in early versions of 802.11), it was possible to

S. Szott and K. Kosek-Szott are with AGH University of Science and Technology, Kraków, Poland, e-mail: {szott, kks}@agh.edu.pl.

P. Gawłowicz, J. Torres Gómez, A. Zubow, and F. Dressler are with the School of Electrical Engineering and Computer Science, TU Berlin, 10587 Berlin, Germany, e-mail: {gawlowicz, torres-gomez, zubow, dressler}@tkn.tu-berlin.de.

B. Bellalta is with the Department of Information and Communication Technologies, UPF Barcelona, Spain, e-mail: boris.bellalta@upf.edu.

This work was supported in part by the Polish Ministry of Science and Higher Education with the subvention funds of the Faculty of Computer Science, Electronics and Telecommunications of AGH University. This work was supported in part by the German BMBF project OTB-5G+ under grant agreement no. 16KIS0985. This work was supported in part by grants WINDMAL PGC2018-099959-B-I00 (MCIU/AEI/FEDER,UE) and SGR017-1188 (AGAUR).

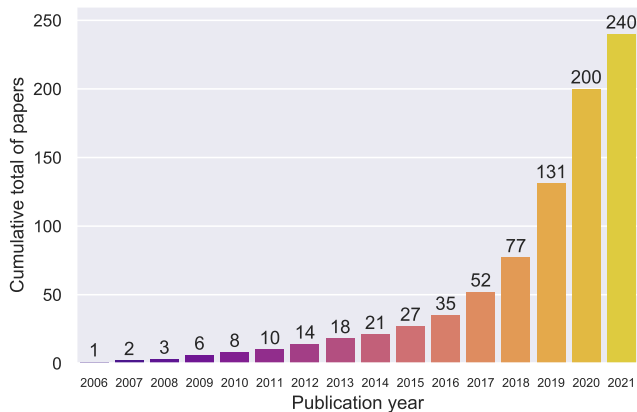

Figure 1. Cumulative number of research papers published in the area of improving WiFi performance using ML and cited in this survey (Sections III to VII). Results for 2021 are limited to the first part of the year.

quickly test all of them and select the best one. Currently, e.g., the introduction of precoding techniques (with beamforming in 802.11ac) requires additional frequent channel measurements towards associated stations, while the interference nulling mechanism (envisioned in 802.11be) will require additional measurements of the channels to stations in adjacent cells. The more active measurements have to be performed, the less channel air-time is available for actual communication.

This increasing complexity coupled with uncoordinated deployment, distributed management, and network densification may negatively impact the operation of future WiFi networks. A candidate approach to solving these performance-related problems is to apply machine learning (ML), a type of artificial intelligence, where “algorithms can learn from training data without being explicitly programmed” [9]. So far, ML-based techniques have been explored for a variety of problems in networking [10]–[12]. Successful solutions can be applied to fields ranging from configuring physical layer parameters to traffic prediction.

Recently, Kulin et al. [11] published a survey on applying ML for general wireless networking while Zhang et al. [13] reviewed almost 600 research papers on ML in 5G systems. However, neither these nor other recent surveys (as we summarize in Section II-D) address in detail the area of WiFi performance improvement using ML. Indeed, WiFi is already too complicated to be covered inside a general survey of wireless networking with ML and requires a dedicated survey. Additionally, a variety of papers in this area have appeared recently (mostly since 2018, cf. Fig. 1). Therefore, motivated by the abundance of research papers in the area of improving WiFi performance using ML and the lack of such a dedicated survey, we have prepared this literature review. We specifically target improving WiFi performance because it is an important, well-defined, and currently relevant issue. Note that there are three non-performance related areas involving both WiFi and ML which are out of our scope:

- dedicated applications of WiFi (unrelated to network access), e.g., device positioning, human activity detection,

- energy efficiency (e.g., power saving protocols), and
- network security (e.g., intrusion detection systems).

There has been broad adoption of ML in these areas and they deserve literature reviews of their own, such as [14], [15]. Furthermore, our survey does not describe how various ML methods operate. There have been also numerous books and research papers on this topic; we refer the reader to papers such as [9], [11] for a detailed (though still wireless networking-related) treatment of these methods.

The overall structure of the survey is depicted in Fig. 2 together with an indication of the ML methods reported in the state-of-the-art papers, for each of the surveyed area. After a short summary of related surveys (Section II), we first investigate core Wi-Fi features in Section III. This section explores, e.g., the use of ML for selecting PHY features, optimizing channel access, configuring frame aggregation and link parameter settings, data rate selection, as well as QoS, admission control, and traffic classification. In Section IV, we study the benefits of using ML in more recent WiFi features such as multiple-input multiple-output (MIMO) and multiband operation, multi-user MIMO (MU-MIMO), spatial reuse, and spectrum allocation. WiFi management is discussed in Section V. Here, we explore ML applicability to access point (AP) selection and association, channel and band selection, management architectures, and determining the health of WiFi connections. In Section VI, we investigate ML-optimized coexistence of WiFi with other technologies: channel sharing, network monitoring, and cross-technology signal classification. Next, in Section VII, we study ML algorithms for multi-hop WiFi deployments: ad hoc networks, mesh networks, sensor networks, vehicular networks, and relay networks. Finally, we elaborate on future research directions in Section IX and conclude the paper with Section X. Appendix A contains the list of acronyms used.

For the presented survey on improving WiFi performance with machine learning, we started with a systematic literature review methodology [16]. First, we searched for WiFi, 802.11, and WLAN as well as machine learning in the paper abstracts in the following databases: IEEE Xplore, ACM, Elsevier, Wiley, and MDPI¹. This yielded 1189 papers, out of which we had to remove out-of-scope papers (e.g., related to device positioning or network security). Next, we added papers manually, usually found through cross-citation analysis. Finally, we identified (and cite in Sections III–VII) over 200 relevant papers in total. Additionally, we reference over 20 survey papers in Section II.

To summarize, our contributions are the following:

- A structured approach of describing the various areas of WiFi performance where ML can be applied: from core WiFi features, through recently added features, to management issues as well as WiFi operating in shared bands with other technologies and in multi-hop topologies.
- A review of over 200 papers in the field, to provide readers with an overview of what has been done and what

¹We could not include SpringerLink at this stage as it does not allow to search within the abstracts of published papers. Papers from this database were added manually.



Figure 2. Organization of the survey and classification of research areas where WiFi network performance can be improved with ML according to the surveyed literature. The classification of ML methods into four categories of learning (supervised, unsupervised, deep, reinforcement) is according to [9].

are the main trends of applying ML to particular WiFi performance problems.

- The identification of open challenges in every area of WiFi performance (at the end of each Section III–VII) as well as the general future research directions in applying ML for improving WiFi performance, to provide readers with an analysis of what remains to be done in the field.

We hope that the survey will be beneficial both for beginners as well as experts in the field, looking for a comprehensive summary of the latest research in the area of improving WiFi performance with ML. We also believe that this survey will guide the readers towards proposing new ideas in this area.

II. RELATED SURVEYS

A number of surveys address the development of ML models to support wireless networks. Reported contributions consider the application ML to both WiFi and application-specific networks, such as wireless sensor networks (WSNs), cognitive radio networks (CRNs), wireless mesh networks (WMNs), and heterogeneous networks (HetNets). WiFi also constitutes an important component of fifth-generation mobile networks (5G) and the future sixth-generation mobile networks (6G), e.g., in the case of cellular traffic offloading. Due to the convergence of both technologies, not only concerning their operation but also in the context of shared unlicensed bands, 5G and 6G-related

surveys provide valuable insights also for WiFi operation. Therefore, in this survey, we also cover some aspects and functionalities from 5G and 6G that are directly related, or equivalent, in the WiFi area.

Regarding the direct application of ML models in WiFi, these surveys are mainly focused on performance indicators and the support of a variety of applications, e.g., human activity detection, indoor localization, and network security. The use of ML in application-specific wireless networks focuses on challenging functionalities like self-configuration, self-healing, and self-optimization in HetNets, bandwidth and coverage in WMN, and dynamic spectrum access in CRN. Regarding 5G, the surveys are mostly focused on interference identification, link quality prediction, traffic demand estimation, and network management. Additionally, they address the problem of unlicensed spectrum sharing between 5G or 6G and incumbent technologies, like WiFi. All these surveys partially overlap with our literature review. However, since none of them focus exclusively on Wi-Fi, neither the level of detail, contents organization nor the number of works covered are comparable with our survey.

A. WiFi-related Surveys

Surveys of WiFi performance-indicators cover mostly WiFi data analytics for network monitoring [17] and quality indicators accounting for user satisfaction [18]. Concerning the WiFi analytics, reported ML models are used to extract useful knowledge from big data streams produced over large-scale wireless networks [17]. Additionally, ML-based solutions to support the estimation of QoS, quality of experience (QoE), and their cross-correlation (QoS-QoE) are surveyed in [18]. Concerning WiFi-based applications, indoor localization [14], [19]–[21] and human activity detection [22] are the two main covered areas. ML-based techniques are illustrated to detect, recognize, and categorize complex patterns in order to support these applications.

Security in WiFi is also a relevant concern addressed in surveys [15], [23]. Considering that WiFi is ranked as the most deployed wireless technology, numerous attacks exploiting its vulnerabilities have been observed. In this direction, ML models are used to develop autonomous and accurate intrusion detection systems (IDSs) for WiFi networks.

B. Wireless Communications-related Surveys

Wang et al. [9] present an interesting survey, in which the thirty-year history of ML is reviewed. It addresses the fundamentals of supervised learning (SL), unsupervised learning (USL), reinforcement learning (RL), and deep learning (DL). Additionally, it summarizes the use of ML in many compelling applications of wireless networks, e.g., HetNets, cognitive radio (CR), Internet of things (IoT), and machine to machine (M2M) communications. However, their use in IEEE 802.11 networks is only briefly mentioned. Additionally, the use of ML models for the layer-specifics' operation is not covered.

The applications of ML supporting physical (PHY), medium access control (MAC), and network layers are also reported

in [24] for wireless communication networks. Novel computing/networking concepts are also addressed like multi-access edge computing (MEC), software-defined networking (SDN), and network functions virtualization (NFV). ML and RL models are also illustrated for several networks types such as 5G, low-power wide area networks (LPWANs), mobile ad hoc networks (MANETs), and Long Term Evolution (LTE) networks. Additionally, the survey provides a brief overview of ML-based network security. However, once again, the area of 802.11 networks is only briefly touched upon.

Sun et al. [10] survey a variety of applications of ML models for resource management at the MAC layer, networking and mobility management in the network layer, and localization in the application layer. This survey also identifies conditions for applying ML models to assist developers in wireless communication systems. The utility of ML techniques in WiFi scenarios is illustrated to implement power saving mechanisms in APs and indoor localization applications.

Several other surveys address the use of ML models in specific wireless networks like WSNs [25], CRNs [26]–[28], and MANETs [29]. These surveys summarize the support of ML models to specific-related problems on these networks like prolonged lifespan in WSNs, feature classification in CRNs, or routing in MANETs. Only the surveys concerning CRNs discuss the applications of ML models in WiFi networks (e.g., coexistence, performance evaluation, channel selection, signal identification). However, specific details concerning the integration of ML techniques and WiFi mechanisms are only superficially covered.

C. WiFi and 5G/6G-related Surveys

In the 5G area, surveys focus on the PHY, MAC, and network layers to account for interference identification, link quality prediction, and traffic demand estimation [11]. Through ML, patterns are automatically extracted and trends are predicted to optimize parameter settings at different protocol layers. Using these patterns, a variety of effective solutions are also used to:

- analyse and manage mobile networks in several directions, e.g., network state prediction, network traffic classification, call details mining, and radio-signal analysis [30];
- improve the performance of mobile systems [13] and IoT [12];
- identify wireless modulations/technologies [31];
- provide fair and efficient spectrum sharing in 5G [32], as well as in future 6G [33];
- maximize the potential of unlicensed bands for Industry 4.0 applications [34].

D. Summary

State-of-the-art surveys report the wide applicability of ML models for wireless networks. Table I summarizes the presented surveys per addressed technology, scope, and remarking their corresponding WiFi-related topics.

Specifically, in the *WiFi area*, the reported surveys are application-oriented focusing on human activity detection algorithms, indoor localization mechanisms, and network

Table I
EXISTING SURVEYS CONCERNING WiFi-RELATED TOPICS AND ML MODELS.

Network	Ref.	Main scope	Addressed WiFi feature	Year
WiFi	[17]	Large-scale network monitoring	WiFi analytics	2020
	[18]	Quality indicators accounting for user satisfaction	WiFi quality indicators	2020
	[14]			2020
	[19]			2019
	[20]	Indoor localization	Application-oriented	2019
	[21]			2018
	[22]	Human activity detection		2017
	[15]	Intrusion detection	WiFi security	2021
	[23]			2016
	Wireless networks (IoT, CRN, M2M, MANET)	[9]	Performance improvement in a variety of wireless networks like HetNets, CRNs, IoTs, and M2M	Insufficient details concerning Wi-Fi functionalities
[24]		Performance improvement in the PHY/MAC/Network layers as well as novel computing/networking concepts (MEC, SDN, NFV)		2020
[10]		ML models to support resource management, networking and localization in wireless networks	Power saving mechanisms for WiFi infrastructure, indoor localization mechanisms	2019
[26]		Decision making and feature classification in CRNs	Collaborative coexistence of WiFi networks with other technologies, performance evaluation, dynamic channel selection	2013
[27]		ML models to support cognitive radio capabilities	Collaborative coexistence of WiFi networks with other technologies	2013
[28]		ML models to support cognitive radio capabilities	WiFi signal identification	2010
WiFi and 5G/6G	[11]	Broad survey covering data science fundamentals, 5G, Wi-Fi, CRN General networking concepts like interference recognition, network traffic predictions, and MAC identification	Insufficient details concerning WiFi functionalities	2020
	[32]			2020
	[35]	Coexistence mechanisms in 5G networks	Coexistence of 5G and WiFi	2018
	[13]	Mobile and wireless networking research based on deep learning	Indoor localization applications and signal processing in WiFi networks	2019

security issues. In the *wireless networks area*, the surveys in general provide few details concerning the use of ML models to improve performance of the 802.11 protocol family. The most often surveyed topics are the coexistence of WiFi networks with other technologies, its performance evaluation, channel selection mechanism, and signal identification in the context of cognitive radio technologies. Finally, concerning the *5G/6G and WiFi area*, in the surveys the conception of spectrum sharing mechanisms to articulate coexistence mechanisms between the two networks is mostly covered. Therefore, the lack of a dedicated WiFi performance survey coupled with the variety of research papers addressing the specifics of using WiFi with ML (Fig. 1) have motivated our work, which we hope will be valuable to the research community.

III. CORE WiFi FEATURES

The new IEEE 802.11 amendments introduce a variety of functionalities for ensuring robust network operation. The

current state of the network is available through performance metrics both at the user as well as the AP level, along with historical data. The availability of this information provides a favorable environment for ML methods. In the literature, many ML solutions have been proposed for 802.11's PHY and MAC layers to adaptively optimize the internal parameters of WiFi's core features in dynamic scenarios (Table II). Additionally, the capability of ML-based methods to gain knowledge, generalize, and learn from past experience allows conceiving smart systems using augmented functionalities of the IEEE 802.11 standard. In this section, we cover core WiFi features (such as channel access, rate selection, frame aggregation settings, mitigating interference) and summarize the open challenges.

A. Channel Access

Channel access mechanisms are perhaps the most often addressed topic concerning the improvement of WiFi performance with ML. Proposed optimizations refer mostly to the

Table II
SUMMARY OF WORK ON IMPROVING THE PERFORMANCE OF CORE WIFI FEATURES WITH ML.

Area	Ref.	ML category	ML mechanisms	Year	Evaluation method	
Channel access (Section III-A)	[36]	RL	QL	2012	Simulation	
	[37]	RL	PDS	2015	Theoretical	
	[38]	SL	RF	2019	Simulation	
	[39]	RL	QL	2019	Simulation	
	[40]	SL	fixed-share	2019	Simulation	
	[41]	RL	QL	2020	Simulation	
	[42]	RL	QL	2020	Simulation	
	[43]	SL	DT	2020	Simulation	
	[44]	RL	QL	2020	Simulation	
	[45]	RL	QL	2021	Simulation	
	[46]	DL		DRL, DQN, DDPG	2021	Simulation
	[47]	DL		federated DQL	2021	Simulation
	[48]	DL		federated DQL, QNN	2021	Simulation
Link configuration (Section III-B)	[49]	DL	Stochastic learning	2008	Simulation	
	[50]	SL	RF	2013	Simulation	
	[51]	DL	ANN, MLP	2013	Simulation	
	[52]	RL	MAB	2016	Simulation	
	[53]	SL	RF	2018	Experimental	
	[54]	SL	ANN	2020	Experimental	
	[54]	RL	ANN	2020	Experimental	
	[55]	RL	MAB	2020	Experimental	
	[56]	DL		DQN	2020	Experimental
	[57]	Online learning		TS	2020	Simulation
	[58]	RL		QL	2021	Simulation
[59]	DL		DQN	2021	Experimental	
Frame format, packet aggregation (Section III-C)	[60]	DL	ANN	2009	Simulation	
	[55]	SL	M5P, RFR	2019	Simulation	
	[61]	SL	RF	2020	Simulation	
	[62]	SL	M5P, RF	2020	Experimental	
	[63]	SL	ANN	2020	Experimental	
	[64]	SL	SVM	2021	Simulation	
Traffic prediction (Section III-D)	[65]	USL	EMA	2010	Experimental	
	[66]	SL	NB, NBT, J48DT, SVM	2012	Experimental	
	[67]	SL	NB, NBT, J48DT, SVM	2015	Experimental	
	[68]	SL	RT	2015	Experimental	
	[69]	DL	ANN	2019	Simulation	
	[70]	ML	DPPL	2019	Theoretical	
	[71]	DL	ANN	2019	Simulation	
	[72]	DL	RNN	2019	Experimental	
	[73]	RL	QL	2019	Simulation	
	[74]	RL	SARSA	2020	Simulation	
PHY features (Section III-E)	[75]	SL	SVM	2006	Experimental	
	[76]	DL	ANN	2011	Experimental	
	[77]	SL	MLP, SVR, DT, DF	2020	Experimental	
	[78]	DL	RNN	2020	Experimental	

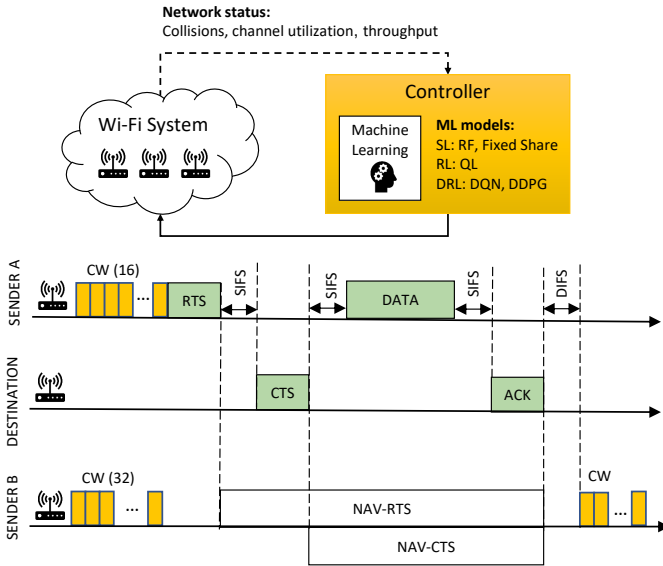

Figure 3. WiFi channel access (DCF) supported by ML models. Dashed arrows represent observation and solid lines represent actions.

basic 802.11 MAC protocol, i.e., the distributed coordination function (DCF), which is the baseline mechanism to avoid collisions among devices when accessing a common radio channel [79].

The main parameter responsible for the performance of DCF is the contention window (CW). It defines the range from which stations randomly select their waiting periods (i.e., the backoff counter) to avoid collisions when accessing the channel. Larger CW values reduce collisions, but increase idle times, which in turn reduces throughput. Smaller CW values increase the chance for a node to transmit, but also increase the collision probability, thereby reducing throughput. Determining proper CW values to maximize throughput by reducing both collisions and idle time periods is the focus of multiple research studies, where SL and RL models are typically applied. Loss functions and rewards are addressed in the form of reduced collisions [39], [45], increased difference between successful and collided frames [36], improved channel utilization [38], increased successful channel access attempts [40], [48], throughput [46], network utility [80], and a combination of throughput, energy, and collisions [37]. As summarized in Fig. 3, SL [38], [40], RL [36], [37], [45], deep reinforcement learning (DRL) [39], [46], [48], and federated learning (FL) [47], [48] models are applied to the IEEE 802.11 standard [37], [48] and its amendments, most importantly 802.11ac [38], 802.11e [36], [43], 802.11n [40], and 802.11ax [39], [46]. We provide a summary of the major findings next.

In high-density 802.11ax WLANs, RL with the intelligent Q-learning based resource allocation (iQRA) mechanism is considered by Ali et al. [39]. Instead of resetting the CW value whenever the channel is idle (as in DCF), CW calculated by considering the channel collision probabilities according to the channel observation-based scaled backoff (COSB) protocol [81]. In this direction, the cumulative reward (accounting for the

probability of collisions) is minimized by optimally adjusting a policy to update the CW size. The iQRA mechanism increments or decrements CW (according to COSB), finding a balance between optimal actions (concerning the best policy to reduce the collision probability) and exploring new actions to account for the dynamicity of WiFi environments. Results obtained from the ns-3 network simulator for both small (15 station) and dense (50 station) networks show that the proposed solution outperforms the baseline 802.11ax protocol in terms of throughput while delay remains similar.

Considering as a reward the difference between successful transmissions and collisions, the work in [36] implements a programming paradigm called adaptation-based programming (ABP). ABP is used to optimize the specifics of RL concerning two possible actions: halve the CW size or leave CW unchanged after a successful transmission. Simulations performed in ns-2 with 20 stations showed a reduction of the total number of dropped packets by four.

The random forest (RF) algorithm is applied in a supervised manner to balance the minimum CW size among users and accounting for fair channel access [38]. The algorithm departs from monitoring channel variables (i.e., busy time, channel occupancy by the user, a number sent frames) to build a decision tree regarding the variety of settings. The algorithm is implemented in indoor 802.11ac scenarios with up to 8 nodes. Throughput, latency, and fairness are improved by 153.9%, 64%, and 19.34%, respectively, when compared to the 802.11ac standard.

The size of the CW can be also adjusted by directly increasing the access to the channel through the fixed-share algorithm [40]. CW is derived by weighting a set of possibilities on the CW range predefined in advance, where the larger the weight, the larger the influence of the particular CW value. Whenever a successful transmission occurs, the weight for users with the largest CW is reduced to increase the chances of transmissions, and the weight of users with a less CW is increased (the contrary occurs after a collision). With this mechanism, a balance is achieved between aggressive (small CW) and non-aggressive (large CW) users to achieve better channel access probabilities among users. Simulations in ns-3 randomly deployed senders show that in a heavily loaded scenario (100 users), throughput is improved by 200%, and the end-to-end delay is reduced by 33% when compared to DCF.

Addressing the scalability of 802.11ax networks, a DRL model is applied to provide stable throughput for an increasing number of stations [46]. A centralized solution is applied for two trainable control algorithms: deep Q-network (DQN) and deep deterministic policy gradient (DDPG). A three-phase algorithm is designed to (1) evaluate the history of collision probabilities, (2) the training of both DRL models by maximizing the reward (throughput), and (3) their deployment in the network. The algorithm is implemented using ns3-gym [82] with a single AP and up to 50 stations. Compared to the 802.11ax standard, which leads to a decreased network throughput up to 28%, the two algorithms exhibit a stable throughput value for an increasing number of stations.

A post-decision state-based (PDS) learning algorithm is

applied in [37] to take advantage of previous knowledge of the system components such as the CW and the transmission buffer occupancy. In contrast to Q-learning (QL), PDS achieves faster convergence to optimally compute the CW when asserting its value in specific states. For instance, when the channel is free and the station is waiting to transmit, it is certain that the CW will be reduced by one. In such a case, the corresponding transition probabilities do not have to be learned, thereby increasing the convergence speed by eliminating exploration actions. The solution exhibits enhanced throughput, expressly with moderate network load, in comparison to the Q-learning algorithm, the 802.11 standard, and alternative deterministic mechanisms like exponential-increase exponential-decrease (EIED).

The CW can be also adjusted considering user fairness metrics [48]. To that end, FL and Q neural network (QNN) models are implemented in APs and stations, respectively, as a distributed method. Considering that each station will have random initialization of its QNN parameters, some stations will use a more aggressive strategy to get access to the channel (small CW), which in turn will block the transmissions of these stations initialized with a less aggressive strategy (large CW). The AP obtains a global model of the QNN through FL and later broadcasts it to stations. Simulation results for a single AP and a total number of stations up to 50 show that throughput is improved by 20% when compared to the DCF.

Considering user fairness, an improved DQN is trained for distributed deployment at stations [45]. The DQN improvement is achieved through rainbow agents [83], which incorporate double DQN, prioritized reply, duelling networks, multi-step learning, distributional RL, and noisy nets. The ns-3 simulation results, for 32 nodes transmitting at a constant rate of 1 Mbit/s, show that the proposed solution achieves results close to an optimal solution and it is superior to an RF-based method.

Driven by the needs to distinguish between traffic priorities, DCF is extended to enhanced distributed channel access (EDCA) in the 802.11e amendment to support QoS [84]. To that end, new medium access parameters are introduced per traffic class (access category): CW, arbitration inter-frame space (AIFS), and transmission opportunity (TXOP) Limit. The AIFS accounts for the waiting period before starting a transmission or invoking a backoff counting. The TXOP Limit specifies the time limit on a granted TXOP [85]. AIFS together with the CW account directly to balance the trade-off between delay and throughput. In this direction, a three-phase scheme is implemented in [43] to select the best combination of CW and AIFS supported by ML. In the first two phases, a range of AIFS and CW values are selected relying on decision tree algorithms like J48 for classification and M5 for prediction. Then, in the third phase, the best combination for AIFS and CW are derived. Simulation results exhibit high accuracy on the throughput prediction when varying the CW range, AIFS, and the total number of stations.

Accounting for channel priority, in the EDCA distributed scheme, a QL model is implemented to infer network density and adjust the CW value [42]. In EDCA, the CW is set to be smaller for high priority traffic like voice and video. The optimal CW value is derived for the four different traffic

priorities defined by EDCA. Simulation results are derived in the ns-3 simulator, where the throughput per traffic type is improved in comparison to the standard EDCA mechanism.

Additionally, collisions can be avoided when implementing channel access mechanisms where users are scheduled per time slots as indicated in [41]. In this approach, each node stores a table consisting of the available time slots in which a given frame to be transmitted. The available time slots are selected by an RL method to find appropriate actions when occupying the channel.

Finally, Kihira et al. [44] consider a channel access problem between two APs: the protagonist, which is equipped with an agent, and a second AP called the ‘outsider’. In the paper, the time is divided in slots, where both APs can decide to transmit independently. Therefore, the goal of the agent in the protagonist AP is to find the transmission probability that maximizes its throughput based on learning the behavior of the outsider AP. To do so, the authors rely on a robust adversarial reinforcement learning framework, that uses game theory to model the interactions between the two APs, and is able to learn the best transmission policies through Q-learning.

B. Link Configuration

In response to growing user demands, the IEEE 802.11n/ac/ax amendments implement high-throughput wireless links through dedicated features at the PHY and MAC layers [57]. For example, IEEE 802.11ax provides data rates up to 9 Gbit/s using eight spatial streams (SSs) and 160 MHz channels. Such high data rates are achieved through a variety of functionalities at the PHY layer including channel bonding, multi-SS transmissions, the use of short guard interval (SGI), and high modulations (1024-QAM for 802.11ax) [52], [86], [87]. At the MAC layer, frame aggregation and block acknowledgment are the two main features for improving the maximum link throughput.

Link configuration, in the form of selecting appropriate PHY and MAC parameters, is required to achieve optimum throughput for given network and channel conditions. Consider rate adaptation, i.e., the selection of MCS values for each transmission, which needs consider fluctuating channel conditions. In dynamic WiFi scenarios (e.g., due to user mobility or interference), rate adaptation deals with the following counteracting mechanisms: (i) on one hand, high data rates may lead to high error rates when decoding the transmitted bits, thereby reducing throughput; (ii) on the other hand, reducing the data rate may incur poor channel utilization and thus also reducing throughput. It is then appropriate to evaluate the trade-off between transmission errors and channel utilization by applying ML models, particularly to deal with the varying channel conditions in WiFi networks. Fig. 4 depicts how ML models can be used for rate selection. In the following, we summarize the contributions in the area of support the optimal selection of MCS and SGI values, and a variety of trade-offs at the PHY.

1) *Rate Adaptation*: Rate adaption solutions reported in the literature predict the probability of successful transmissions for each MCS candidate. Then, the data rate is selected

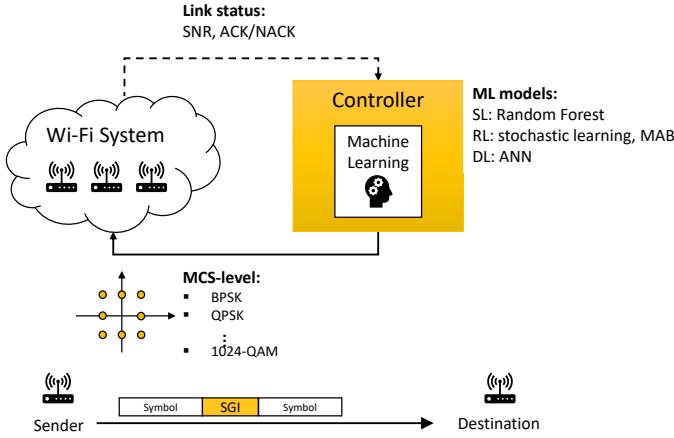

Figure 4. Rate selection supported by ML models. Dashed arrows represent observation and solid lines represent actions.

corresponding to the MCS with the best result. They either rely on the estimated signal to noise ratio (SNR) [50], [54] or follow a cross-layer approach based on acknowledgment (ACK) or negative acknowledgment (NACK) feedback [49], [51], [58]. SNR is preferred to timely update the channel status when dealing with station mobility, e.g., in case of vehicular ad hoc networks (VANETs) [50]. However, more accurate solutions are obtained when updating the channel status based on the ACK and NACK feedback [50].

Using the SNR metric, throughput can be improved through a two-level data rate search algorithm based on an artificial neural network (ANN) model [54] or using an RF algorithm [50]. In the former, the ANN is implemented as a coarse estimator to find a possible set of best data rate candidates. In the second stage, a fine-grained solution is devised to identify the best candidate from this set. With this solution, at least a 25% improvement was reported in mobile scenarios when compared to baseline rate adaptation algorithms. In [50], the RF algorithm is implemented for the uplink data rate adaptation in VANETs. The algorithm uses the position and velocity of cars to estimate the SNR in the link between the APs and the vehicle. The algorithm predicts the probability of successful transmission for each possible data rate candidate, and then selects the best candidate. With this approach, the goodput is improved at least by 27% in comparison to reported solutions like collision-aware rate adaptation (CARA).

However, the unpredictable impact of fast fading decorrelates the correspondence between SNR and packet losses due to their large fluctuation in short time periods. To deal with this problem, Joshi et al. [49] implement a variant of the stochastic automata rate adaptation (SARA) without assuming any predefined relation between SNR and packet losses. The algorithm updates a selection probability vector in a one-to-one mapping with the available data rates. The learning procedure is implemented to adjust this vector, with throughput being the reward function, while the ACK frames are used as a feedback to account for the channel condition. Thus, the probability corresponding to the rate that produces the best reward is updated. After selecting the data rate resulting with

the highest probability of successful transmission, throughput can be improved by around 15% in comparison to other reported solutions.

Thresholds to detect successfully and non-successfully received packets can be derived through ML models to improve aggregate throughput also by counting received ACKs [51]. Based on the auto rate fallback (ARF) algorithm, the data rate is increased or decreased when the total number of ACK are higher than a given threshold. Using an ANN, these thresholds are adjusted when estimating their correlation to the achievable throughput considering the total number of stations, channel conditions, and traffic intensity. Using this solution, the aggregated output can be increased by 10% in a network of 10 stations.

Rate selection can also be performed by first identifying the channel condition, e.g., using supervised learning [53] or Q-learning [58]. In the former, the channel condition is classified as residential or office environments, then the proper MCS level can be selected. The model is trained based on selected characteristics of an 802.11 frame's preamble. In the Q-learning model, the MCS level is adjusted based on the total number of received ACKs. Observation of the network state is conceived through the timeout events, which is referred to the total number of not received ACKs. Simulations are implemented in ns3-gym [82] considering a dynamic scenario, where the receiver node moves away from the sender at a speed of 80 m/s [58] with throughput comparable to Minstrel [88].

Alternatively, MCS can be selected considering also the available bandwidth and selected spatial streams. Chen et al. [59] applies the double deep Q-network (DDQN) model using goodput as a reward and also includes further learning techniques like prioritized training, history-based initialization, and adaptive training interval. Results show that the proposed method, implemented in hardware, significantly outperforms default mechanisms.

2) *SGI Adaptation*: Selection SGI values is another link configuration mechanism which can be supported by ML models [57]. The SGI assumes two (802.11ac) or three (802.11ax) different values. The selection between them can be implemented through Thompson sampling (TS), an online learning mechanism, to deal with the fluctuation of channel quality (signal interference, signal fading, and attenuation). A TS model was tested through simulations in ns-3 for an 802.11ac network with up to 40 stations. The SNR was varied randomly in the range of 20–60 dB and the results showed a slight throughput improvement compared to the static SGI settings.

3) *PHY Layer Trade-offs*: There are a variety of trade-offs inherent to the PHY layer: wider channels versus more interference, MCS versus required SNR, frame aggregation versus packet loss, etc. These trade-offs may be jointly addressed to optimize the overall performance using ML methods such as multi-armed bandit (MAB) [52], [89]–[91] and DL [56].

The authors of a series of papers [52], [89]–[91] design an online learning-based mechanism based on the MAB framework for link configuration in IEEE 802.11ac networks. The solution takes into account both network load and channel conditions,

and uses a MAB-based adaptive learning (AL) methodology (i.e., the ϵ -greedy algorithm) along with fuzzy logic. Through this approach, the network performance is improved thanks to the ability to explore multiple configurations. The resulting implementation exhibits an increased throughput (up to and 358 %) when compared to reported solutions like MU-MIMO user selection (MUSE) [89].

Addressing several parameters from the PHY and MAC layers simultaneously (channel bonding, MCS, and frame aggregation settings), a two step algorithm is conceived in [56] to improve throughput. First, a deep neural network (DNN) is applied to estimate throughput assuming different link parameter settings. Then, a predictive control-based search algorithm is applied to find the optimal parameter values which maximize throughput. Experimental results are obtained through IEEE 802.11ac client boards installed on laptops. Results exhibit superior performance concerning delay and throughput in comparison to three baseline algorithms.

Rate adaptation algorithms are also designed for specific applications in industrial networks [74]. An RL-based mechanism is used to solve the trade-off between reduced packet losses and increased rate of transmission. The learning procedure is implemented through the state action reward state action (SARSA) algorithm, and the balance between exploration and exploitation is conceived through the ϵ -greedy algorithm. With this approach, packet losses are reduced by 6 % when compared to non-RL-based algorithms. Additionally, to account for the industrial network, packet delay is assessed to illustrate the improved performance of the implemented RL-based approach.

C. Frame Aggregation

Frame format and packet aggregation are two main techniques directly impacting the communication efficiency in terms of useful transmitted data and overhead introduced by headers and preambles. User data packets are amended with PHY and MAC layers headers to account for the proper functioning of the protocol. The resulting frame inevitably reduces the available resources to transmit useful data due to the introduced overhead. In this regard, ML models are proposed to maximize the efficiency when increasing the frame size by aggregating packets with a unique sequence for the preamble, that is, reducing the number of individual transmissions (Fig. 5) [92].

In this case, efficiency is analyzed in terms of errors produced during the packet decoding. Larger frames can lower the impact of overhead but they can be also more susceptible to transmission errors. This trade-off is addressed by frame aggregation techniques to derive the optimum frame size to maximize efficiency. To that end, the 802.11 standard introduces two basic aggregation methods: aggregated MAC service data unit (A-MSDU) and aggregated MAC protocol data unit (A-MPDU) [2]. These aggregations can also be used together [85].

The A-MSDU method is more efficient but more prone to errors than A-MPDU, since it contains only one frame check sequence (FCS) accounting for all the aggregated frames. The A-MPDU method is more robust but introduces more overhead as it generates several FCSs, one per each sub-frame. However,

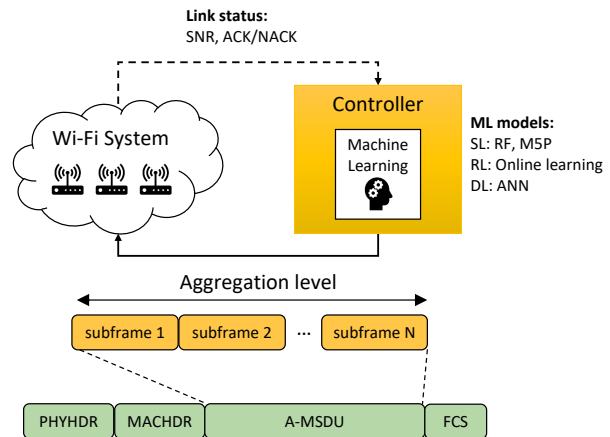

Figure 5. Configuring frame aggregation settings supported by ML models. Dashed arrows represent observation and solid lines represent actions.

their dynamical adjustment in the 802.11 standards is not designed to deal with the varying channel state information (CSI) in wireless links.

To optimally select the frame size under dynamic conditions, ML techniques are used, including supervised learning [61], [62], [64], online learning [55], and ANN [60], [63] models. Their use is reported in the 802.11n standard to maximize goodput [61], [62], in 802.11 networks to maximize throughput [60], and in 802.11ac for addressing the energy-throughput trade-off [55]. Furthermore, ML methods are also reported to estimate the aggregation levels in 802.11ac, which is not typically accessible by non-rooted mobile handsets [64].

Specifically, a low computational complexity technique is implemented in the downlink direction in [61]. An random forest regressor (RFR) model is used to properly combine the aggregation and MCS settings. Exhibited results are obtained for small and medium-sized networks up to 20 stations. This solution lowers the rate of re-transmission resulting in goodput improved by 18.36 % when compared to legacy 802.11 aggregation mechanisms.

Aggregation methods supported by ML are also designed for software-defined WLANs (SD-WLANs) as an artificial intelligence (AI)-based operating system [62]. The M5P and the RFR models are implemented due to their low computational complexity. Intended to provide a frame length that maximizes goodput for each user, their training is performed with real measurements in a WiFi scenario with up to 10 stations. Here, the RFR model presents the highest goodput improvement (55 %) when compared to the A-MSDU mechanism.

The MCS level can be also predicted through an ANN as presented in [63]. The model is trained in a client device by receiving packets from an AP using all the available rates within a 1 s time window. Estimated rates are then used to compute the best aggregation level using a previously designed (non-ML) method [93]. Regarding throughput, the implemented solution outperforms baseline algorithms by at least 13 %.

Designing aggregation level estimators can help in queue backlogging. Hassani et al. [64] use ML techniques on obtained hardware-level timestamps to determine the aggregation level

implemented at a given AP. A logistic regression estimator model is used to devise an accurate aggregation level estimator with low computational complexity. The solution is implemented in non-rooted hardware as client nodes, where the achieved accuracy to determine the proper aggregation level is close to 100 %.

Frame aggregation settings can also be consider the associated energetic costs [55]. Based on the channel condition (given by the SNR value), the aggregation level is selected as the ones with the less frame error rate (FER) to reduce the energetic costs caused by re-transmissions. The solution is a combination of an online learning algorithm to define a set of suitable aggregation levels and fuzzy logic to select the most suitable level from that set, by estimating which frame size would have the lowest FER. Following this approach, the resulting energy efficiency with 10 stations is 14 % better when compared to the standard use of A-MSDU and A-MPDU mechanisms.

Finally, channel condition and impact of collisions are jointly addressed in [60] to adjust both the frame size and CW. An ANN model is trained with frame size-throughput patterns to provide a gradient indicating the direction of the optimal frame and the CW sizes. Simulation results, provided for 10 mobile users, show that throughput is when compared to the case that only the frame size is optimized and without considering the optimal CW.

D. Traffic Prediction

Traffic prediction techniques play a major role in assisting network management operations for better short and long term planning. Proper planning, using methods such as traffic forecasting, congestion control, power saving, bandwidth allocation and buffer management, leads to improved user QoE. For instance, based on the predicted traffic, APs may perform better load balancing, while a given AP may perform adequate admission control.

Real-time traffic prediction becomes a challenging problem in WiFi networks due to varying channel conditions, changing network topologies, and random user traffic. Traffic estimation is also dependent on several other parameters, such as the total number of users in the network, the SNR on the link, or the communication capabilities of users and APs [77]. In such scenarios, ML models are used to deal with the diverse conditions of WiFi networks, otherwise intractable through analytical methods. As summarized in Fig. 6, ML models are used to augment legacy 802.11 devices through support vector machine (SVM) [75], recurrent neural network (RNN), multilayer perceptrons (MLP), support vector regressor (SVR) and polynomial regression [94], decision tree (DT), RF [77], or ANN [76], [78].

Specifically, the solution proposed in [75] trains an SVM to predict the traffic evolution one step ahead. Besides, by recursively applying the one-step-ahead solution, traffic estimation for l -step-ahead is also conceived. The SVM model is implemented as a Gaussian radial basis function and trained with 100 samples to predict the next 100 samples. Through the SVM model, the error to predict the upcoming traffic is

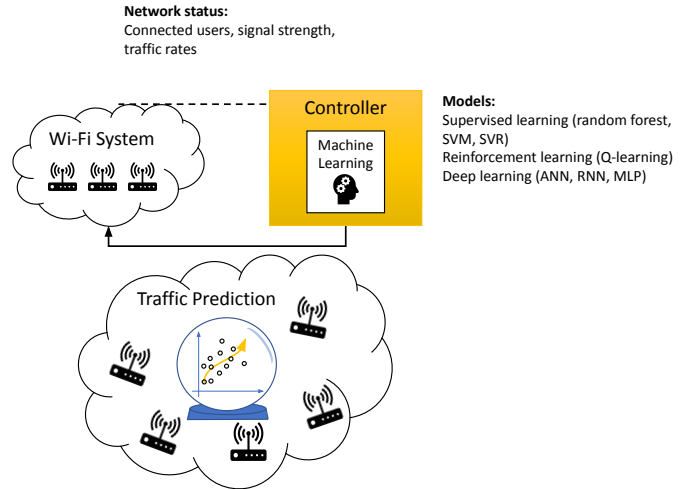

Figure 6. Illustration of the traffic prediction capabilities of ML models. Dashed arrows represent observation and solid lines represent actions.

reduced at least by 33 % when compared to the performance of the ANN.

Khan et al. [77] analyzed the most suitable ML models to predict traffic among MLP, SVR, DT, and RF. To train these models, several features are extracted from simulation and real data (using the Wireshark network trace) namely the number of connected users, signal strength, modulation scheme, data rate, inter-arrival time, packet arrival rate, number of re-transmissions, and several other channel parameters. The solutions are implemented in a WiFi network consisting of 10 users and a single 802.11 AP. The reported prediction accuracy presents a maximum value of 96.2 %, 94.5 %, 93.3 %, and 91 % using MLP, DT, RF, and SVR, respectively. The study also analyses the complexity of these mechanisms in real-time schemes by reporting the time elapsed for each model. The highest time-consuming model is MLP followed by RF, SVR, and DT.

Dealing with large-scale traffic prediction, the work in [78] deploys an RNN on an SDN framework. The model is trained to improve the prediction accuracy by minimizing its mean square error (MSE) metric. The model is evaluated with 23 nodes interconnected through 38 different links. The resulting prediction error is 10 units of magnitude-order less than feed forward neural network (FFNN) and traditional linear prediction models like autoregressive moving average (ARMA).

Barabas et al. [76] use ANNs operating in the multi-task learning (MTL) paradigm to improve prediction accuracy. Following this paradigm, three upcoming traffic values are predicted instead of one. The network is trained with three tasks simultaneously, which improves the accuracy of the network. The learning procedure is implemented through multi-resolution learning (MRL) by decomposing the traditional learning into three stages. A wavelet transform is used to provide this decomposition by filtering the data set into its low and high-frequency band representation. The network is trained first with coarse resolution, then with finer ones, and finally with the original resolution of the data set. Results exhibited

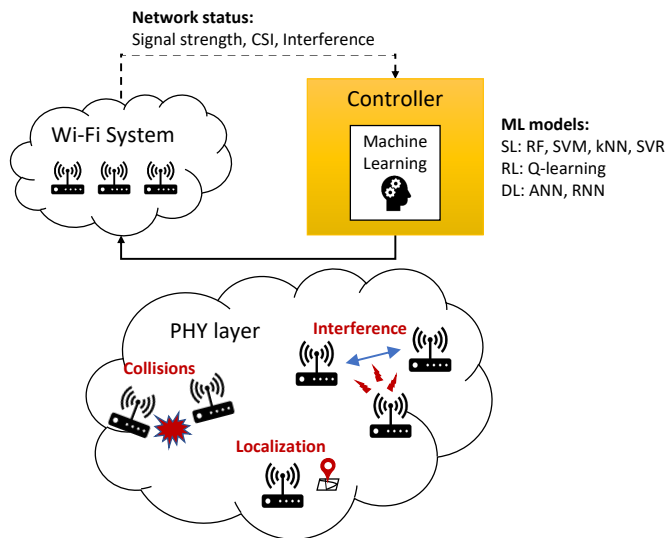

Figure 7. Mitigating negative PHY effects with ML models. Dashed arrows represent observation, solid lines represent actions.

the best performance when having 4 nodes, 5 hidden neurons, and 3 outputs.

Finally, network congestion levels are also predictable with SL and USL models [94]. Based on captured data attributes like the number of clients, throughput, frame retry rate, and frame error rate, SVR and polynomial regressor models are applied to predict the same values for a certain location, day, and time. These predicted values are then fed to the expectation maximization (EM) algorithm to predict congestion levels by forming three different clusters. Each cluster is identified with high, medium, and low congestion levels based on the numeric value of the clustered samples. Results are presented after collecting data in a network of over 1200 APs distributed in an area of 1.17 km² with more than 80 buildings. The obtained accuracy is 24 %, 50 %, and 26 %, for a low, medium, and high level of congestion.

E. PHY Features

At the PHY layer, a variety of actions can be supported by ML techniques to improve the performance of WiFi networks. Issues that can be addressed include collision detection characterization [65] and its mitigation [66], [67], interference power-level characterization [70] and its mitigation [73], signal de-noising [69], source detection to improve spectral efficiency [95], prediction of signal strength variability [72], or the enhanced modeling of the PHY and MAC layer interactions to improve throughput [68]. As depicted in Fig. 7, a variety of ML models are available to deal with these effects and the variable conditions of WiFi networks in terms of the total number of users, power level, CSI, etc.

To estimate the number of collisions in the channel, the activity of nodes in the network can be modeled as a hidden Markov model (HMM) [65]. The approach is to use RL techniques to learn the parameters of such models, then to mathematically evaluate the probability of collisions. The

transition probabilities are assessed through the expectation modification algorithm (EMA). Based on the derived transition probabilities, the probability of collisions is directly computed based on the estimated total number of senders that simultaneously transmit. Results are provided by estimating deferring probabilities performed by deploying 7 APs and an equal number of clients over two floors of a building. The estimated deferring probabilities exhibit a good correspondence with the real condition scenario.

To reduce collisions, produced by the ambiguous decoding of request to sends (RTSs)-like frames, the solutions in [66], [67] implement an ML model. A Bloom filter is conceived to decode the RTS frames, and a supervised ML technique is used to solve their inherent ambiguity with an accuracy larger than 99 %. The ML is implemented through a variety of algorithms such as naive Bayes, naive Bayesian tree, J48 decision tree, and SVM. Additionally, this solution is connected to a second, $K\varepsilon$ -greedy algorithm for channel allocation. The integration of both algorithms allows improving the performance 3.3 times over the legacy 802.11 operation.

The interference level can be estimated by modeling the network through a determinantal point process (DPP). Saha and Dhillon [70] present such a model, in which a supervised learning process is implemented to evaluate the total number of active transmitters that may interfere with each other as well as their locations. Interference is then evaluated by providing the cumulative density function (CDF) for the total number of active users. This is then used when modeling the power of the interference signals through a path-loss model for each link. Results illustrate a good match with the theoretical model Matérn hard-core processes (MHCP) regarding the CDF of interference levels.

Interference can be also mitigated by jointly optimizing the transmitted power of APs and the channel allocation policies [73]. An RL model is implemented with the Q-learning algorithm to maximize throughput in dense WLANs. The model is trained through a learning process of reduced total iterations driven by an event-triggered mechanism, i.e., whenever the network status changes due to the mobility of users, the learning process is called again to optimize power and channel allocation policies. Results are derived based on the deployment of 15 APs, where a 16 % throughput improvement is obtained in comparison to traditional power and channel allocation mechanisms.

The received signal strength can be predicted through deep learning techniques [72]. In an RNN model, encoder and decoder components are implemented to capture the CSI and predict its variability, respectively. The model is trained according to the three different schemes to balance the trade-off between convergence speed and performance: guiding training which used the current measured signal strength (resulting in faster convergence), unguided training which uses the predicted signal strength (resulting in better prediction performance), and curriculum training which combines both previous methods to balance the speed and prediction performance. With the curriculum training scheme, the resulting prediction accuracy of the signal strength is improved when compared to linear regression and auto-regression methods.

The quality of the received signal can be also improved at the PHY layer using DL techniques [69]. With an ANN, the preamble of the 802.11 family protocols can be de-noised by unfolding the useful signal from noise in the spectrogram domain (i.e., time-frequency domain). It is proposed that the spectrogram is processed as an image, where the ANN is used as a convolutional de-noising auto-encoder to estimate the originally emitted patterns. Using this approach, the derived reconstruction accuracy is around the 85 %.

The spectral efficiency of WiFi transmissions can also be improved when avoiding the exposed terminal problem. To that end, senders can be identified according to their CSI to later predict whether they will interfere with each other [95]. To implement such an identification mechanism, a model is trained through k-nearest neighbor (kNN) and ANN with 20 wireless nodes in indoor scenarios, where an accuracy of 90 % is achieved with at least 30 samples per node. Besides, in case of reduced total samples, better performance is obtained with the kNN model.

The PHY layer can be also modeled in unison with the MAC layer to characterize the impact of different features on observed throughput [68]. The selected input features are received power, channel width, spectral separation between users, traffic load, and physical rates. The idea is to find a mathematical function that maps input features to throughput values supported by supervised ML. This mathematical function then becomes a black box representation of a given link to later optimize throughput. The learning phase, which is used to obtain this function, is derived through regression techniques: regression tree, gradient boosted regression tree (GBRT), and SVR). In particular, it is found that GBRT and SVR provide the most accurate results.

F. Open Challenges

From the multitude of papers addressing core WiFi PHY and MAC features, we have identified several open challenges related to studying more realistic settings, removing common simplifying assumptions, and improving ML-based solutions. We describe these challenges below.

First, there is a need for more *more realistic simulations*. Several reports address the intention to provide simulation testbeds with less simplifying assumptions. For instance, the inclusion of more realistic channel and traffic models, variable channel condition per user, dense networks, or the addressing of multi-hop networks are some remarked requirements to conduct further research as remarked in [36], [39], [40], [46], [49], [74], [84], [85].

Second, studies needed to consider *overall network performance*. Currently, papers address specific optimization parameters under specific conditions. Although some work is reported to simultaneously address a variety of parameters of WiFi networks (cf. Section III-B3), an overall perspective of network functioning, which would account for optimization criteria in several layers simultaneously, has been not conducted yet. While improved performance can be achieved when addressing cross-layer designs [96], solutions to posed problems in this direction are rather difficult to solve by analytical means

due to the variety of related parameters. As yet unexplored, this constitutes a promising research direction to address by ML models.

Third, only a few papers provide details on the *impact of user mobility* on communication performance [58], [60]. However, considering the growing number of connecting mobile devices to WiFi networks (e.g., phones, tablets, even vehicles), further insights can be provided to better characterize the influence of movement on the network performance.

Finally, many reported works remark future directions concerning the *improvement of ML-based solutions* to:

- provide accurate ML models (additional loss functions) [40],
- reduce the coordination overhead between agents in decentralized solutions [37],
- further integrate ML models into network controllers for proactive management [76],
- further study the impact of network status parameters on traffic prediction [52], [75], [90], and
- increase complexity of ML models to better characterize network functioning [58], [61], [65], [70].

IV. RECENT WiFi FEATURES

In a push for higher and more efficient performance levels, recent WiFi amendments such as 802.11ac [144], 802.11ax [3], and 802.11be [145] support new advanced and complex techniques such as multi-user communications (OFDMA, MU-MIMO) [146], spectrum aggregation (channel bonding, multi-link operation) [147], spatial reuse, and multi-AP coordination [5]. All these techniques promise high-performance gains in both throughput and latency and pose new challenges regarding how to use them. These challenges can be solved, or at least alleviated, using ML methods (Table III).

A. Beamforming

Transmissions in the millimeter wave (mmWave) 60 GHz shared band are a specific WiFi use case aimed at greatly increasing the transmission rate in line of sight (LoS) communication scenarios, both short-range (indoor) and long-range (outdoor), the latter known as fixed wireless access (FWA) [148]. To cope with the increased attenuation in this band, beamforming of transmissions is required. This functionality was first introduced to WiFi in 802.11ad and later extended in 802.11ay.

A key problem of 802.11ad/ay networks, which can be solved using ML, is finding the optimum beam sector pairs (i.e., beam alignment) between transmitter and receiver (Fig. 8). Alignment is derived from a beam sweeping procedure, which can take up to tens of milliseconds and needs to be periodically repeated. To facilitate the beam sector pair selection, Chang et al. [101] propose to replace the standard method of exhaustive beam search with one of three neural network (NN)-based algorithms proposed to predict the optimal beam sector, including the use of historical data. This work is then extended in [111], where the training duration is reduced through a combination of SL-based feature extraction and RL-based training beam selection. Meanwhile, Polese et al. [112] developed DeepBeam,

Table III
SUMMARY OF WORKS ON IMPROVING THE PERFORMANCE OF RECENT WI-FI FEATURES WITH ML.

Area	Ref.	ML category	ML mechanisms	Year	Evaluation method
Beamforming (Section IV-A)	[97]	Statistical learning		2017	Theoretical
	[98]	SL	RF	2017	Simulation
	[99]	NN	CNN	2018	Theoretical, experimental
	[100]	DL	DNN	2019	Simulation
	[101]	DL	DNN	2019	Simulation
	[102]	SL	CNN, Conv. LSTM, RF	2019	Simulation, experimental
	[103]	RL	QL	2020	Simulation
	[104]	N/A	N/A	2020	Simulation
	[105]	DL	CNN	2020	Experimental
	[106]	DL	DNN	2020	Simulation
	[107]	SL	RF	2020	Simulation
	[108]	SL	DT, RF, SVM	2020	Simulation, experimental
	[109]	DL	DRL	2020	Experimental
	[110]	DL	DRL	2021	Simulation
[111]	SL, DL	CNN, DRL	2021	Simulation, experimental	
[112]	DL	CNN	2021	Experimental	
Multi-user communication (Section IV-B)	[113]	SL	SVM	2014	Simulation
	[114]	RL	MAB	2019	Experimental
	[115]	RL	QL	2019	Experimental
	[116]	DL	DNN	2019	Simulation
	[117]	SL	DNN	2020	Experimental
	[118]	DL	DQN	2020	Simulation
	[119]	DL	DQN	2021	Simulation
	[120]	RL	QL	2021	Experimental
	[121]	DL	DNN	2021	Experimental
	Spatial reuse (Section IV-C)	[122]	RL	IState-GPOMDP	2008
[123]		RL	QL	2009	Simulation
[124]		RL	MAB	2016	Experimental
[125]		RL	QL	2017	Simulation
[126]		RL	MAB	2019	Simulation
[127]		RL	MAB	2019	Simulation
[128]		RL	MAB	2019	Simulation
[129]		SL	MLP	2020	Simulation
[130]		RL	QL	2020	Simulation
Channel bonding (Section IV-D)		[131]	RL	MAB	2017
	[132]	RL	MAB	2019	Simulation
	[133]	RL	SARSA	2019	Experimental
	[134]	RL	MAB	2019	Theoretical, simulation
	[135]	DL	DQN	2020	Simulation
	[136]	DL	DQN	2020	Simulation
	[137]	RL	MAB	2020	Experimental
	[138]	RL	MAB	2021	Experimental
	[139]	SL	NN	2021	Simulation
	[140]	SL	GNN	2021	Simulation
Multi-band, network MIMO, and full-duplex (Section IV-E)	[141]	SL	DNN	2019	Simulation
	[142]	DL	Monte-Carlo/DDPG	2019	Simulation
	[143]	DL	DNN	2020	Simulation

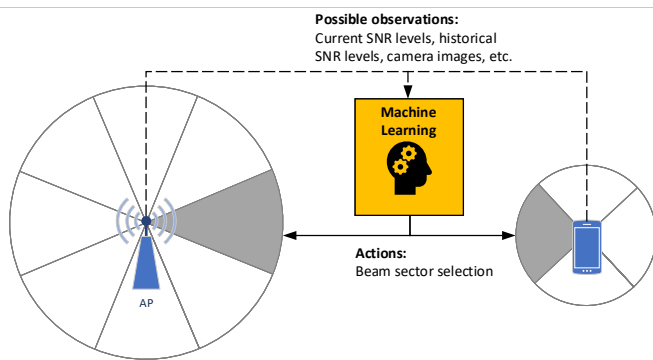

Figure 8. Example of beam sector alignment in IEEE 802.11ad/ay networks: 8-sector AP and 4-sector client station.

a framework for beam selection which replaces the time-consuming beam sweeping procedure with inferring the beam sector to use through convolutional neural network (CNN)-based deep learning based on passive listening to other transmissions.

Alternatively, improved ML-based beam alignment predictions can be performed with the use of camera images. Salehi et al. [105] show that visual information can significantly reduce the time required to establish the best beam pairs. The application of camera images was also shown by Nishio et al. [102], where ML was able to accurately and rapidly predict received power, which is the necessary information needed to find beam sectors. Camera-based predictions of link outage can be made with DRL and lead to improved handovers in mmWave networks [109].

Since the range of mmWave bands is short, 802.11ad/ay APs may need to be densely deployed for certain use cases. Under such network densification, beam coordination, and interference management becomes necessary. Mohamed et al. [97] propose an architecture to reduce cross-beam interference by applying statistical learning to construct a radio map of the network environment, which serves as input for beam selection. In this scenario, signalling is carried over the WiFi network in the 5 GHz band through a centralized AP controller. Zhou et al. [100] propose a DNN-based solution to optimize the beams in a centrally-managed AP deployment. Their solution is able to achieve nearly the same performance as an optimization algorithm at a fraction of the computational time.

A related problem in dense deployment scenarios is the association between user stations and APs, especially since next-generation stations will have multi-homing capabilities (i.e., methods allowing sustained connectivity to multiple APs). This leads to an interesting user-to-multiple APs association problem, which can be solved using ML methods. Ly Dinh et al. [110] consider a generic WLAN where users can autonomously learn, using their own DQN, which APs to connect to and using which band (sub-6 GHz or mmWave).

Once appropriate 802.11ad/ay beam sectors have been found, rate adaptation is required. MCS selection for mmWave transmissions relies on appropriate channel classification, i.e., determining whether a channel is LoS or non-line of sight

(NLoS) This classification can be augmented with ML, as shown in [98], where classification is done based on the random forest technique. Predicting the statistical characteristics of a channel can also be useful and there are many papers focusing on the PHY layer (regardless of the wireless technology). For example, Bai et al. [99] use a trained CNN to predict the statistical characteristics of a channel for any given (indoor) location for technologies using massive MIMO.

Alternatively, rate adaptation can be based on typical metrics available in commercial off-the-shelf (COTS) devices. Aggarwal et al. [108] predict optimal MCS settings using three ML models: DT, RF, and SVM. They conclude that RF provided best results and outperformed SNR-based rate selection strategies. This approach was then extended in the learning-based beam and rate adaptation (LiBRA) framework [107], where the same ML-based classification methods are used to determine which of the two adaptation methods (rate selection or beam selection) give better performance for a given link.

The data rate of mmWave links can be improved by better channel estimation techniques. Lin et al. [106] combine transceiver location information with a DNN to evaluate the channel frequency response. This approach decreases the number of transmitted pilot signals leaving more room for user data.

Finally, in terms of channel access, 802.11ad introduces a new, hybrid MAC with contention-free and contention-based periods. The definition of the resource scheduler is out of the standard scope and remains an open research challenge [104]. Azzino et al. [103] propose an RL-based approach to find the optimal duration of the contention-free period by observing the time-varying network load. Their scheme is able to preserve the throughput for the allocated streams, while leaving more resources for contention-based traffic.

B. Multi-user Communication

With the IEEE 802.11ac amendment, and the support of downlink MU-MIMO transmissions, Wi-Fi opened the door for multi-user transmissions, i.e., simultaneously transmitting to different stations in the same TXOP. Then, both downlink and uplink MU-MIMO was introduced by IEEE 802.11ax, as well as orthogonal frequency-division multiple access (OFDMA). OFDMA divides the available bandwidth into different sub-channels, called RUs, which are then allocated to other users. Both MU-MIMO and OFDMA will also play an important role in future IEEE 802.11be networks. In IEEE 802.11be, beyond extending Wi-Fi capabilities by using 320 MHz channels and up to 16 spatial streams, some improvements such as the allocation of multiple RUs to the same user will be introduced.

The most significant challenge in multi-user communications is identifying and creating groups of compatible stations that, when simultaneously scheduled, result in an improvement of network performance. This is a complex non-linear problem and so suitable to be tackled using ML techniques due to the need to choose a particular group of stations and configure their link parameters with only partial information in a rapidly changing environment. Fig. 9 shows the case where an AP

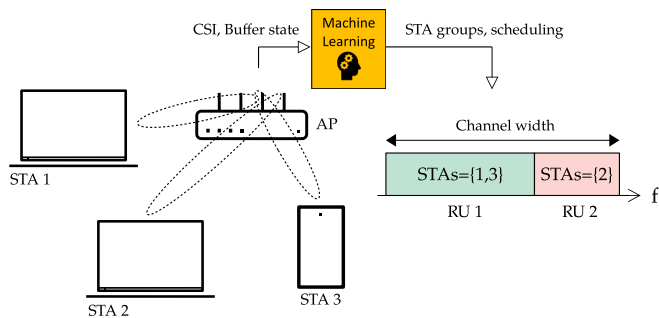

Figure 9. The ML agent is in charge of finding groups of compatible stations and schedule transmissions based on past experience.

empowered with an ML agent is in charge of taking these scheduling decisions. First, it must learn that station (STA) 1 and STA 3 can belong to the same MU-MIMO group. Then, given the AP has data to transmit to all three stations, the ML agent has to decide how to allocate the different available RUs to the stations. In this example, it has agreed to allocate a larger RU to STA 1 and STA 3 for a MU-MIMO transmission, and a smaller one to STA 2.

Several papers address the problems of user selection, link adaptation, and channel sounding overhead reduction in MU-MIMO-enabled WLANs using a variety of ML strategies. Karmakar et al. [114] implement an ϵ -greedy strategy to find the best configuration (group and link parameters) using past experience. The authors of [113] use an SVM classifier to develop a robust MCS selection procedure. Reducing the channel sounding overheads using DNNs to compress CSI at each STA and decompress CSI at the AP is presented in [117], showing a significant reduction of the required airtime. Finally, a different approach is considered in [115], [120], where a policy gradient approach is applied to determine if a certain client will benefit from participating in MU-MIMO transmissions. In this case, the policy function is represented using a neural network consisting of two convolutional layers. In all cases, significant performance results are obtained by improving the network throughput.

Regarding OFDMA, in case of AP-initiated transmissions, the AP must determine the group of stations scheduled at each TXOP, and which is the best RU allocation to them. Alternatively, in the case of uplink transmissions, stations may be allowed to select the RU which they will use for transmission. These problems are considered in [116], [118], [119] using DRL techniques. In [118], [119], the authors focus on the uplink case, and propose a decentralized RU selection method using DRL (i.e., a CNN based DQN) that provides much higher gains when compared against the case when RUs are selected randomly (as proposed in IEEE 802.11ax). An opposite case, i.e., only AP-initiated downlink transmissions, is considered in [116] where DRL-based scheduling is implemented. It takes into account per-station channel quality and traffic information as inputs and different objective policies. Results confirm the potential of the use of ML for scheduling in OFDMA systems.

It is important to remember that OFDMA-based channel

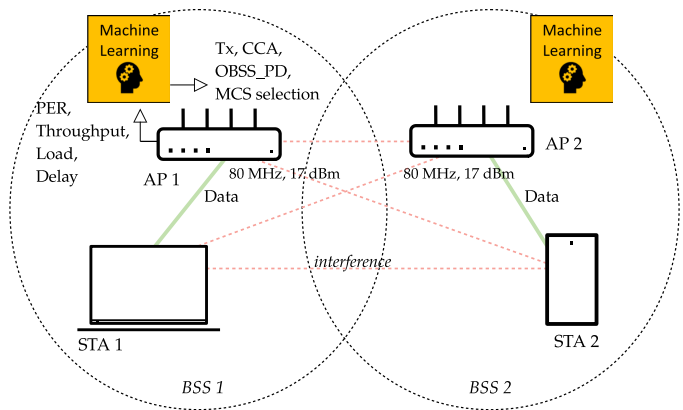

Figure 10. An AP empowered with ML is able to learn from experience which are the best SR configuration to maximize its own, or the overall network, performance.

access is a common feature for Wi-Fi and 5G, which was adopted by WLANs after it was successfully applied in the cellular domain. In the following papers ML is used to the address the several problems in OFDMA-based cellular networks: fair scheduling [149], [150], carrier frequency offset (CFO) estimation for uplink transmissions [151], [152], inter-network interference control [153], and resource allocation [154]. They implement RL [149], [150], [153], supervised deep learning [151], unsupervised deep learning [152], and a genetic learning algorithm [154] to support performance optimization. We believe that these papers may provide interesting insights and guidelines for researchers working in the Wi-Fi domain.

Finally, in [121] joint MU-MIMO and OFDMA optimization is addressed using DL. The proposed solution, called DeepMux, is executed at the APs and relies on DNNs to minimize the impact of channel sounding and find a near-optimal resource allocation policy. Experimental results show gains of up to 50% in throughput using DeepMux.

C. Spatial Reuse

The IEEE 802.11ax amendment first introduced spatial reuse (SR) to Wi-Fi networks. The main goal behind this mechanism is to allow concurrent transmissions between devices that belong to different basic service sets (BSSs). When a device detects an ongoing transmission, it must first decide whether another concurrent transmission is possible, and in case it is, which transmission power to use to avoid disrupting the ongoing one [8]. The IEEE 802.11ax SR solution offers good performance gains, despite its conservative design. Therefore, the use of ML techniques to make such a mechanism adaptive to the current scenario and help decide when and how a device detecting an ongoing transmission can benefit from a spatial reuse opportunity should result in even higher gains.

Fig. 10 shows the case of two neighbouring APs that, empowered by ML agents, can find a suitable configuration for both of them (i.e., the configuration that gives them the highest possible throughput) to share spectrum resources. In this case, we assume both prefer to use the same 80 MHz channel but are transmitting at low power. In this case, they maximize

mutual spatial reuse opportunities in front of other options such as the use of non-overlapping channels (less bandwidth) or transmitting at high power (higher MCSs) but causing the other BSS to defer.

The use of ML solutions to tackle the SR problem has raised some attention in recent years. Most of the works implement RL techniques for learning the best configuration for each ML agent-empowered AP on-line. Q-learning is used in [123], [130], and MABs are used in [124]–[128]. All these papers share the concept of multiple agents that either do not share information or only share partial information (i.e., the action performed and the obtained reward) and learn by interacting through the environment. As shown in the referred papers, in multi-agent scenarios where the agents compete with each other without collaborating, convergence may be hard or impossible to achieve. There are also papers using SL techniques, such as NNs [129], [155], to help with the selection of proper SR parameters (transmission power and sensitivity levels) given the characteristics of the scenario are known.

In the following, we overview some of these papers, as they are illustrative to understand how ML can be used to improve SR operation in WiFi. Timmers et al. [123] use a Q-learning algorithm to optimize power, transmission rate, and clear channel assessment (CCA). States are defined as a combination of transmission power, interference, and the MCS used, and actions consist of changing the transmission power and MCS. Agents are placed at every device and act selfishly. Q-learning is also used in [130] to improve the 802.11ax's spatial reuse mechanism. In this case, the considered Q-learning solution aims to learn the best decision (i.e., transmit concurrently or wait) given the agent knows the current interferers. Interestingly, the authors also consider non-stationary scenarios and tackle that situation by increasing the learning rate of the less-chosen actions, which results in a rapid adaptation to the environmental changes.

Using [125] as a starting point, where a stateless Q-learning solution is introduced, in [127], different MABs action-selection strategies are considered (ϵ -greedy, EXP3 [156], upper confidence bound (UCB) [157], and TS [158]) to deal with channel selection and transmission power allocation. Two strategies to take actions are also examined: 1) concurrent – all networks take actions simultaneously, and 2) sequential – only one network changes its configuration at a time. Results show that optimal proportional fairness can be achieved even if the different networks operate selfishly (i.e., they aim to maximize their throughput) without sharing information. Concerning the different MAB techniques, the use of sequential action taking between actors reduces the throughput variability at the different BSSs. However, this comes at the expense of lower throughput values. More details regarding the use of MABs for improving decentralized SR decisions are provided in [126] where it is considered that the different ML agents can communicate and share the performance obtained when playing a certain action. In this case, it is possible to apply utility functions in the online optimization process that directly target network fairness, such as max-min, effectively reducing those cases where some BSSs are starved due to the selfish operation of the others.

Supervised learning techniques such as MLP and DTs are

considered in [129] to help the selection of SR parameters at both the AP and stations. The models are trained offline using a dataset that covers multiple scenarios and configurations. A different approach is considered in [155], where a central controller able to configure the entire Wi-Fi network is considered. A NN is then used to propose configurations to all BSSs so spatial reuse is maximized. The NN takes into account the correlation function between the throughput achieved by the different devices in the network and their associated link layer parameters.

Lastly, a completely different approach to achieve SR is taken in [124] by considering the use of directional transmissions. In this paper, the selection of the antenna orientation is tackled as a non-stationary MAB problem. The authors implement the system using software-defined radio (SDR) wireless open access research platforms (WARPs) showing its correct operation, as well as that their solution is resilient to co-channel interference.

D. Channel Bonding

The option to enable channels wider than 20 MHz was introduced in IEEE 802.11n, where up to 40 MHz channels were supported. The IEEE 802.11ac and IEEE 802.11ax amendments further increased the maximum channel width to 80 and 160 MHz, respectively. Increasing the channel width will continue with IEEE 802.11be, where up to 320 MHz channels will be allowed. Using wider channels allows for higher transmission rates and therefore higher performance. However, in dense scenarios, it may notably increase contention between neighbouring BSSs, which may cause the opposite result. Therefore, correctly deciding when to use a wider channel and what should be its size is necessary for successfully improving WLAN performance. Unfortunately, there is no single answer to the previous question. It depends on each specific scenario, including the number and position of contending devices, the load of each BSS, and the available channels.

ML techniques can help solve such a situation by learning the best channel allocation and bonding configurations in a given scenario. Online learning seems a natural option in this case, especially if RL techniques and prediction models are combined to foster a rapid convergence [132]. For example, Fig. 11 shows the case where an agent learns from experience which actions to perform given that the environment is found in a particular state (i.e., the state may be defined by the occupancy of the different 20 MHz channels) every time the primary channel becomes idle. In this case, the agent has learnt that the best action when all four 20 MHz channels are idle is to transmit in the first 40 MHz primary channel, but not in the secondary 40 MHz channel. Similarly, when the secondary 40 MHz channel is busy, the AP has learnt the best action is to wait until the 40 MHz secondary channel becomes idle to perform a 80 MHz transmission.

Out of the box MABs are mainly used to decide which are the best channel widths to be used when no further information, neither from the network nor from the user requirements, is considered, and the goal is to maximize WLAN performance [133], [134], [138]. Then, when traffic loads

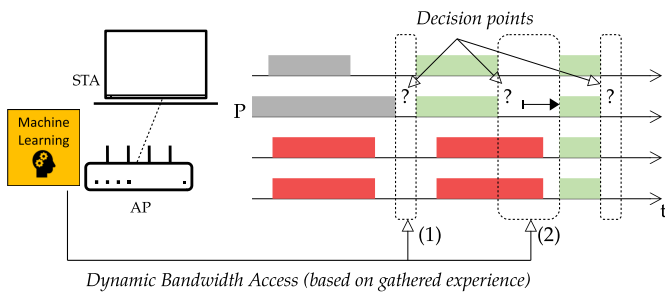

Figure 11. An ML-enabled AP that aims to learn which is the best set of actions that maximize its own performance. The primary channel is identified as P. Grey rectangles illustrate idle channels, red – busy channels, green – AP transmissions.

are also a parameter to be taken into account, as well as other performance metrics such as delay and throughput, DRL techniques are considered [135], [136]. Lastly, SL techniques are also used to predict future states [137], [139] and so be able to react in advance in case when predicted values are below the expectations.

Karmakar et al. [133] show that the default dynamic channel bonding operation can be improved by considering the individual needs of each station, as well as the access category (AC) they are using, selecting the most appropriate channel widths to use. With that goal in mind, a MAB algorithm, UCB, is used to learn when the use of secondary channels is required. Testbed results show that the proposed solution can provide gains higher than 100% in some cases. Similarly, in [134], the authors aim to learn from a trial and error perspective (i.e., exploring) which are the best channels and bonding strategies to use, including both contiguous and non-contiguous 20 MHz channels. The proposed mechanism, called iterative trial and error (ITE), includes different states depending on both the actions taken and the reward obtained. Exploration is implemented in ITE using an ϵ -greedy strategy. The proposed mechanism is implemented in WARP nodes. Results show the ITE mechanism outperforms the default ϵ -greedy mechanism, and improves the performance of static bandwidth channel access (SBCA) and dynamic bandwidth channel access (DBCA) thanks to its availability to select the channel width properly. Lastly, in [131] hybrid adaptive DBCA (HA-DBCA) is introduced to solve the starvation problem that affects some DBCA devices. HA-DBCA introduces a polling-based adaptive mechanism for contention-free access and uses UCB to identify the stations that are starving, and so allow them to transmit their data during the contention-free access. The channel bonding problem is also modelled as a MAB in [138]. However, in this work, the authors rely on chaotically oscillating waveforms generated by semiconductor lasers to guide exploring the different available actions. Then, dynamically adapting the different thresholds used to select one or another action based on the amplitude of the generated waveform at sampling instants shows that such a technique can outperform default MABs such as UCB and ϵ -greedy in terms of throughput.

DRL is considered in [135], [136]. In [135], the channel allocation problem (i.e., group of selected channels and position of the primary channel) in a scenario with multiple BSSs is addressed. The paper shows that the channel allocated to each BSS should depend on its expected load and performance. Then, considering the goal of minimizing latency, a on-demand channel bonding (DCB) algorithm is proposed that uses DRL along with a multi-agent deep deterministic policy gradient (MADDPG) for training to find suitable channel allocations. Results show that by reducing the channel width in APs with low traffic demands, the delay in the overall network is improved as the channel access contention is reduced. A similar problem is considered in [136], where DRL is used to tackle the channel assignment problem in WLANs with channel bonding. A key aspect of this paper is that the authors consider spatio-temporal changes in traffic demands. Therefore, the DRL solution (i.e., a DQN) has to learn how to adapt to them to offer satisfactory service. To do that, the agent in each AP learns from historical traffic loads when more or fewer channels should be bonded together, trying to minimize the interactions with other BSSs when not required.

The problem of throughput prediction in dense WLANs supporting channel bonding is considered in [139], where several predictors are built using SL techniques that include ANNs, graph neural networks (GNNs), RF regression, and gradient boosting. Both training and validation are performed on an open dataset generated using the IEEE 802.11ax-oriented Komondor network simulator [159]. While the accuracy achieved by the proposed methods demonstrates the suitability of ML for predicting the throughput performance of complex WLANs, more importantly, this work can be easily extended by considering other approaches. The same dataset is used in [140] to predict Wi-Fi performance using a GNNs model that incorporates the deployment's topology information. Finally, the problem of collisions with hidden nodes when channel bonding is used is described in [137], which, as indicated, may cause a reduction in throughput up to 60%. Therefore, a solution to avoid channels with hidden interference issues by predicting its activity in advance is proposed. To do that, APs use a recursive neural network, namely a Metropolis-Hastings generative adversarial network (MH-GAN) technique, that can predict the activity of the neighbouring BSSs. Results confirm that the presented solution, called Smart Bond, can reduce the probability of suffering transmission errors due to hidden nodes, as could be expected.

E. Multi-band, Network MIMO, and Full-duplex

ML techniques are also applied to improve the operation of a wide variety of advanced mechanisms that include multi-band WLAN operation [141], multi-AP coordination [142], and in-band full-duplex [143]. In these papers, we find that both RL and SL techniques are used. For example, DRL is used in [142] to jointly perform channel allocation and AP clustering to maximize the performance of Distributed MIMO transmissions. Similarly, NNs are used in [141] to predict future channel states and so improve the performance of multi-band WLANs, and in [143] to find groups of stations that enable

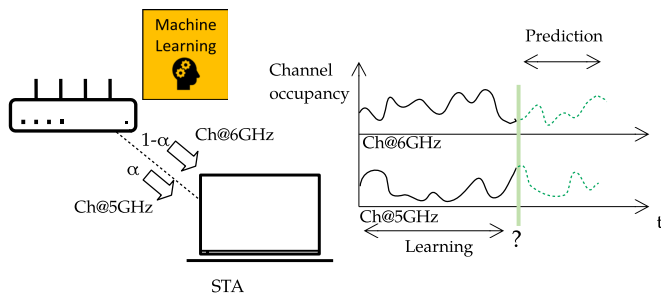

Figure 12. An ML-enabled multi-band AP that aims to determine the best traffic balancing policy based on predicting future channel occupancy values. In the figure, α represents the fraction of the traffic directed to the 5 GHz interface.

full-duplex communication at the APs. In the following, we overview them in more detail.

Fig. 12 shows the case where an ML-enabled multi-band AP has to decide how to distribute the traffic (to a given station) between the 5 GHz and 6 GHz bands. To do that, the agent aims to predict future channel occupancy values at both bands to decide how to use the two interfaces better. For instance, if the occupancy predicted at the 5 GHz band is high, it may choose to turn off such an interface, and use only the one working at the 6 GHz band, thus saving some energy.

How to improve the operation of a multi-band WLAN, i.e., a WLAN equipped with multiple interfaces operating at different bands, is considered in [141]. The description of how their proposal works fits well with the multi-link operation currently under development in the IEEE 802.11be task group and with the synchronous mechanism in particular. In such a scheme, when any of the active backoff instances reach zero, the other interfaces' state is checked, and those idle are bonded together to support the subsequent transmission. However, in many cases, the different interfaces will be busy at that moment. Suppose some of them will become idle soon. In that case, it may be more efficient to wait until that happens and then aggregate these links instead of immediately transmitting using only a single interface. The authors solve this uncertainty by learning and predicting when a given interface will become idle using a probabilistic neural network (PNN), and so supporting the decision of waiting or not.

In [142], the authors consider the joint problem of channel allocation and AP clustering in distributed MU-MIMO for Wi-Fi networks. DRL is considered to solve these two problems aiming to maximize user throughput performance. As pointed out by the authors, both issues are NP-hard, and therefore, only heuristic solutions exist in the literature. The proposed DRL framework consists of an agent, implemented using a DNN, and a distributed MIMO Wi-Fi simulator. Although not explicitly specified, their solution is implemented in a central controller. Results show that using the DRL framework, a 20% improvement in user throughput performance is achieved. Also, it is shown that the DRL framework can attain multiple objectives, such as maximizing throughput and fairness simultaneously.

Finally, full-duplex (in-band) communication allows a device

to transmit and receive simultaneously, thus 'doubling' the channel capacity. In WLANs, a key challenge to solve is the user pairing problem: finding groups of different stations that allow the AP to transmit to one while receiving from another. To solve this combinatorial problem, which becomes impractical when the number of stations is high, in [143] a DL approach is considered through a 'pointer network'. The main benefit of this solution is that the NN does not need to be re-trained when the length of input (e.g., the number of users) changes within an expected range. The authors compare their solution with two other low-complexity methods called greedy assignment and random assignment algorithms, showing how the DL-based solution outperforms them.

F. Open Challenges

This section has covered recent and advanced WiFi features such as beamforming, multi-user communications, channel bonding, spatial reuse, and multi-band. Although quite different, in all of them ML techniques are used mainly either (1) to adapt to the environment through selecting the most proper actions at the right moment, (2) for system-level performance predictions, or (3) to improve the operation of specific mechanisms by completing unavailable data.

Since most of these features are recent, complex, and in development, many aspects are still not considered or considered only superficially. Therefore, there is room for future work in this area either by addressing the problems listed in previous subsections with different ML techniques or by simply picking some of the still uncovered aspects. In the following, we detail some open aspects in the different categories.

First, the success of using *beamforming* in indoor WiFi scenarios will be based on the ability to properly perform beam sector alignment (Fig. 8). Research has shown that ML methods can have a positive impact, but robust solutions available for COTS devices are required, e.g., to minimize latency [148]. For outdoor scenarios, beamforming-aware resource allocation (intra-AP) and resource coordination (inter-AP) methods based on ML need to be updated to the recently released 802.11ay amendment, where FWA is an important use case, which has so far not been researched in depth.

In the area of *multi-user communication*, more works focusing on the use of ML solutions for allocating spatial streams and RUs to active stations are required, especially when mixed with realistic traffic patterns and QoS requirements. Developing techniques that can plan several resource scheduling rounds in advance is required. By considering future traffic estimates, contending devices, and environmental conditions, may help improve the WiFi response to sensitive traffic, improving criteria such as worse-case latency by pre-reserving resources. Moreover, future predictions using ML techniques can improve how channel sounding is implemented, as only stations that will likely be scheduled, will be requested to provide such information.

Many works in the area of *spatial reuse* have considered BSSs operating in a completely decentralized way, so using a spatial reuse opportunity depends only on each individual's

observed inputs. This situation justifies that many papers have considered the use of ML techniques such as MABs or Q-learning to infer which is the best action in a particular situation. However, with IEEE 802.11be, TXOP sharing and cooperative schemes may be enforced, thus requiring a different approach, and so the use of new and different ML techniques, to optimize its operation.

The case of *channel bonding* has been addressed using RL, SL, and DL techniques. All these ML techniques have been able to capture the interactions between BSSs that appear when channel widths change dynamically. Further work is required to test and compare these results with other techniques. However, a more exciting aspect is to couple channel aggregation techniques with OFDMA RU allocation, for which complex DL techniques may be well suited.

Finally, a disruptive new feature introduced by IEEE 802.11be is *multi-link operation*. This will open several exciting challenges, such as which channels to use and how to distribute the different flows between links. ML techniques can also be applied to learn, for example, when is the best moment to perform a channel switch, which link occupancy patterns favour more or less a particular traffic pattern, and how to allocate or distribute flows to links.

V. WiFi MANAGEMENT

WiFi management (including channel and band selection, AP selection and association, management architectures, protection of the health of WiFi connections) are important and complex tasks. Table IV presents a summary of works augmenting Wi-Fi with ML in this area, which we present next.

A. Channel and Band Selection

Channel allocation is an important problem in dense WiFi networks, where a limited set of available channels has to be shared by a large number of co-located WiFi BSSs. Poor channel allocation causes substantial contention among the APs and stations, hence reduces the throughput of each node. Typically, in the proposed solutions, the research goal is to try to assign channels in a way that the APs using the same channel do not interfere with each other (e.g., they are out of each others' interference range) and/or avoid allocating the same channel for highly loaded BSSs (i.e., load balancing). Note that in the of variable traffic load, channel allocation has to be performed periodically.

As depicted in Fig. 13, ML-based algorithms can help in solving this problem, as they provide models that may consider changing interference relations (e.g., due to node mobility) and variable traffic loads (e.g., as a result of nodes becoming active/passive).

Nakashima et al. [161] addressed the channel allocation problem in multi-BSS WLANs by assuming the existence of a central controller that is aware of the global system state, and able to control all APs. To solve the problem of finding a channel allocation that reduces inter-AP overlapping and maximizes the throughput of each BSS, a DRL approach is applied to learn satisfactory channel configurations. First, the interactions between APs, under a certain channel allocation,

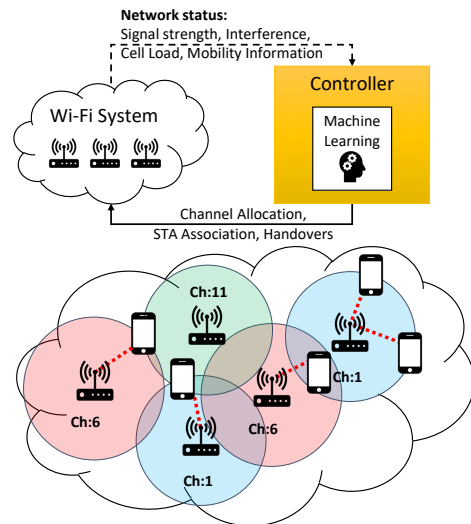

Figure 13. An ML-based network controller determines channel allocation, station association, and handovers. Dashed arrows represent observations, solid lines represent actions.

is represented by means of contention graphs (i.e., channel adjacency matrices). To extract the features of carrier sensing relationships, the authors use graph convolutional networks (GCNs). Then, a DDQN is considered as a DRL method, with ϵ -greedy and spatial adaptive play (SAP) policies to train the neural network. DDQN aims to maximize the throughput of the APs with lowest throughput. The proposed method shows that in a 10 BSS WLAN, the use of a solution which combines DDQN and GCN outperforms random channel allocation.

Jeunen et al. [160] introduce a framework able to passively monitor dense WiFi environments, compute overlapping airtime periods, and detect so-called *bad networks* (i.e., networks that are the main cause of performance degradation in a WLAN). A centralized (SDN-based) network architecture is assumed. To implement the framework, the authors resort to different ML techniques (e.g., least absolute shrinkage and selection operator (LASSO) regression and ordinary least squares (OLS)) as well as other algorithms to extract and rank relevant features from the gathered data, e.g., label propagation algorithm (LPA), Girvan-Newman algorithm (GNA). Results show the presented framework is able to find a new channel allocation that solves the interference problems.

Another DRL-based channel allocation scheme for densely deployed WLANs was proposed in [161]. The learning algorithm is based on DDQN employing a dueling network and prioritized experience replay. Further, two additional features are introduced to improve performance. First, the authors adopt graph convolutional layers in the model to extract essential features of the carrier sensing relationships among the APs (i.e., topology information). Second, they propose selective observation data buffering to prevent over-fitting by reducing the duplication of the sampling data specific to WLAN channel allocation problems. Specifically, they filter experiences to reduce the duplication of data for learning, which can often adversely influence the generalization performance. The simulation results demonstrate that the proposed method

Table IV
SUMMARY OF WORKS ON IMPROVING WiFi MANAGEMENT WITH ML.

Area	Ref.	ML category	ML mechanisms	Year	Evaluation method
Channel and band selection (Section V-A)	[160]	SL	LASSO, OLS	2018	Experimental
	[161]	RL	GCN	2020	Simulation
AP selection and association (Section V-B)	[162]	SL	MFNN	2010	Experimental
	[163]	SL	RF	2011	Experimental
	[164]	RL	DRL, DQL	2021	Simulation
	[165]	SL	RF	2017	Simulation
	[166]	SL	LR, DT	2017	Experimental
	[167]	SL	NN	2018	Simulation
	[168]	RL	MAB	2019	Simulation
	[169]	RL	QL	2019	Simulation
	[170]	DL	DRL	2019	Simulation
	[171]	SL	LSTM	2019	Experimental
	[172]	RL	MAB	2020	Simulation
Management architectures (Section V-C)	[174]	DL	DQL	2019	Simulation
	[175]	SL	RF	2019	Experimental
	[176]	SL	DT	2018	Simulation, experimental
Predicting the health of Wi-Fi connections (Section V-D)	[177]	SL, USL	DT, RF, SVM, kNN	2019	Experimental
	[178]	SL	kNN, NB	2020	Experimental
	[179]	USL	SOHMMM	2021	Simulation

enables the allocation of channels in densely deployed WLANs such that the system throughput increases.

B. AP Selection and Association

The proliferation and densification of WiFi networks often leads to the existence of multiple spatially overlapping WiFi cells. Hence, a station has to choose which of the discovered APs to connect with. The simple association method envisioned in the WiFi standard makes the stations select the AP that provides the strongest signal. Unfortunately, in many cases, this simple approach leads to under-utilization of some APs while overcrowding others. Consequently, AP selection and load balancing approaches have been extensively studied as a way to improve network throughput. For example, a decentralized AP selection procedure was presented in [168], [173], where stations employ an MAB-based approach to dynamically learn the optimal mapping between APs and stations, and hence distribute the stations among the available APs evenly. Specifically, each station independently explores the different APs inside its coverage range, and selects the one that better satisfies its needs. To this end, the authors propose a novel opportunistic ϵ -greedy approach with stickiness that halts the exploration when a suitable AP is found, then, the station remains associated to that same AP while it is satisfied, only resuming the exploration after several unsatisfactory association periods. The authors show that their approach allows increasing the number of satisfied stations and the aggregated network throughput by up to 80% in the case of dense AP deployments (e.g., 16 co-located APs).

Similarly, López-Raventós and Bellalta [172] study MAB-based solutions for the decentralized channel allocation and AP selection problems in enterprise WLAN scenarios. To this end,

they empower APs and stations with agents that, by means of implementing a Thompson sampling algorithm, explore and learn which is the best channel to use, and which is the best AP to associate with, respectively. Using a custom built simulator, called Neko,² the authors show that the proposed learning-based approach outperforms the static one, regardless of the network density and traffic requirements. Moreover, it was shown that the proposed approach can achieve better performance than static strategies with less APs for the same number of stations.

Bojovic et al. [163] proposed a cognitive AP selection scheme, where a station selects an AP that is expected to yield the best throughput according to past experienced performance. The scheme belongs to the family of supervised learning techniques and uses an multi-layer feed-forward neural network (MFNN) to learn the correlation between the observed environmental condition (e.g., SNR, probability of failure, beacon delay) and the obtained performance (i.e., throughput). The authors performed an experimental performance evaluation in an 802.11 testbed and showed that the proposed approach effectively outperforms legacy AP selection strategies in a variety of scenarios. A similar approach of predicting future performance for the sake of AP selection is followed also in [162], [180].

An interesting scheme of user-to-multiple AP association was presented in [164]. The authors proposed two distributed association methods based on Deep Q-Learning (DQL), where a station learns its best set of APs to be connected *i)* solely using local knowledge of the wireless environment and *ii)* with limited feedback from AP. Note that each device is equipped with multiple wireless interfaces. The objective is to maximize the long-term sum-rate subject to multiple constraints

²<https://github.com/wn-upf/Neko>

(i.e., AP load or application QoS constraints). The numerical evaluation revealed that the proposed algorithms improve targeted objectives and enhance fairness among applications.

A centralized approach was proposed by Kafi et al. [169]. Specifically, they proposed an RL-based client-AP association algorithm to enhance the aggregated throughput in dense WiFi networks and hence satisfaction of users. The Q-learning-based algorithm is deployed centrally in an SDN-controller and controls the actual associations of new users as well as performs re-associations of connected stations. As the authors demonstrated through simulations, their approach outperforms the standard 802.11 association procedure when the distribution of users is not uniform and performs similarly when it is uniform.

Pei et al. [165] performed large scale measurements trying to find out which factors affect the WiFi connection set-up process. Specifically, the authors analyzed 0.4 billion WiFi sessions collected using the *WiFi Manager* mobile app from 5 million mobile devices. Their results show that 45% of WiFi connection attempts fail and about 5% of attempts consume more than 10 seconds. Based on the analysis, they developed an ML-based AP selection algorithm that significantly improves WiFi connection set-up performance. The algorithm is based on RF and classifies candidate APs into *slow* or *fast* sets by taking the following features as an input: *hour of the day*, *received signal strength indicator (RSSI)*, *mobile device model*, *AP model*, *encryption enabled*. Based on the classification, a station avoids connecting to those AP classified into the *slow* set. The evaluation results show that the described approach can reduce connection failure to 3.6% and improves the connection set-up time over 10 times.

As shown by Song and Striegel [166], frame aggregation can offer a compact and efficient representation of expected throughput for improving AP selection. Specifically, they demonstrated that the characteristics of sub-frames during frame aggregation can uniquely embody the utilization, interference, and backlog traffic pressure for an AP. Then, using an SL approach, they built simple regression models (based on linear regression and DT regression) to predict the AP expected throughput for better access point selection. According to the presented results, the prediction accuracy is above 80%.

In mobile scenarios, it frequently happens that a station leaves the coverage area with good connectivity of one AP and enters an area covered by another AP. In such a case, the station has to perform a handover from the old AP towards the new AP. A decision about a potential handover operation should be made early enough to avoid low data rate periods or even connectivity outage. ML methods help predict future network conditions, and hence to make correct handover decisions. For example, Feltrin and Tomasin [167] employ ML to predict upcoming handover by making an AP monitor the RSSI of connected stations and use a neural network for specific pattern recognition in the RSSI evolution. The technique provides good prediction accuracy and is resilient to noise, speed, and fading phenomena.

ABRAHAM (mAchine learning Backed multi-metRic Handover Algorithm) [171] is an ML-based proactive handover algorithm that uses multiple metrics to predict the future

location of stations, the future predicted AP load, and, using LSTM, predicts future RSSI values. These predictions are used to optimize the load on the APs by handing over stations to APs to preserve QoS and QoE metrics. The authors use a long short-term memory (LSTM) neural network (a variation of the RNN) as they learn and recognize temporal patterns (e.g., evolution of RSSI). ABRAHAM achieves 139% higher overall throughput compared to the legacy 802.11 handover algorithm.

Han et al. [170] describe a handover management scheme for dense WLAN networks, which is based on DRL, specifically deep Q-network. It enables the NN to learn from user behavior and network status, adapting its learning in time-varying dense WLANs. The handoff decision is modeled as an Markov decision process (MDP) leveraging the temporal correlation property, while the proposed scheme depends on real-time network statistics to make decisions. Using simulation analysis, the authors show that their solution can effectively improve the data rate during the handover process and outperform the traditional 802.11 handover scheme.

C. Management Architectures

Bast et al. [174] used DRL to dynamically optimize network slice configuration in WiFi networks. A slice configuration consists of multiple parameters, e.g., CCA sensitivity level, MCS, and transmit power. Therefore, the action search space grows with the number of active slices in the network. Interestingly, in the proposed approach a selected action does not consist of absolute configuration values, but increasing or decreasing the current parameters. The authors start with a simple DQN agent and further enhance it with DDQN, experience replay, as well as fitted Q-learning to improve convergence speed and stability. Using the ns-3 network simulator, they show that the proposed solution can achieve the same optimal performance found as with an exhaustive search. Finally, DDQN can optimize at run-time, without the need for AP deployment information or knowledge about coexisting networks.

aiOS [62] is an AI-based operating system for SD-WLANs (i.e., the control plane). It embeds state-of-the-art ML toolboxes to provide a global intelligence platform, which is at the same time driven by AI and designed to drive future AI-powered applications and services. The authors presented a proof-of-concept implementation of aiOS and validated it by implementing several low-complexity ML models for adaptive frame length selection in 802.11-based SD-WLANs. The proposed approaches improve the aggregated network throughput by up to 55% as evaluated with a real-world testbed.

Lyu et al. [175] collected large-scale AP usage data in a university campus WiFi system, which contains over 8000 APs and serves more than 40,000 active users. The data collection was performed over a period of more than two months. With the collected data, the authors conducted extensive spatio-temporal analytics on the data set including AP load (i.e., the number of associated users) and AP traffic throughput (i.e., the amount of traffic consumption within a time period). The authors observed a so-called *idle phenomenon* that prevails throughout the whole trace. Specifically, a large portion of APs

remain unused, without any user association regardless of day or night. Second, the AP load follows a long tail distribution (i.e., most APs serve only a few users, while a small number of APs serve hundreds of users), hence, the AP utilizations are imbalanced. The authors propose a new management system, named LAM (large-scale AP management), where the unused APs are switched-off intelligently according to the underlying user association conditions. LAM leverages a machine-learning algorithm to predict the AP load over time based on historical AP association records. Using diverse algorithms (including RF, SVM, kNN, and DT), the authors show that the load prediction accuracy can reach as high as 90%. In addition, more than 70% of power energy can be markedly saved, with over 92% of WiFi coverage guaranteed. These savings translate to \$59,000 per year in their university WiFi system.

An SDN-based WiFi control system is considered to manage a group of APs in [181]. The central controller is able to configure channels and transmission power for the APs in the network. Decisions on how to configure the network are taken after learning from the collected data. A set of ML-based techniques are used, for example, reduced error pruning trees (REPTs) – to make predictions of future WiFi and non-WiFi activity (such as microwave ovens) so better configurations can be deployed. The use of the framework reduces channel congestion by up to 47%.

D. Predicting the Health of WiFi Connections

The unlicensed bands are becoming crowded with dense and uncontrolled deployments of WiFi networks, generally managed by different users. These environments have exacerbated the effects of well-known pathological conditions such as hidden terminals, flow starvation, and performance anomaly. Unfortunately, these problems become increasingly difficult to detect in a real complex scenarios. Specifically, while performance degradation is a common symptom of these pathological conditions, they have different causes and would require different solutions. ML seems to be a right toolset to be applied towards the detection of individual impairments, as it can handle a large amount of raw measurement data and learn to deduce the current operation regime (e.g., using classification methods). Therefore, Gallo and Garlisi [176] provide an automatic diagnostic tool, Wi-Dia, for detecting causes of performance impairments by recognizing the wireless operating context. Wi-Dia follows a data-driven approach and exploits machine learning methods for classifying WiFi pathological conditions (e.g., hidden nodes and flow starvation). It uses features related to network topology and measures channel utilization without impacting regular network operations. The classifier was jointly trained using simulated and experimental data. Specifically, the authors took the advantage of the flexibility of network simulators as well as the realistic details of wireless testbeds. As results show, Wi-Dia achieves high detection accuracy of pathological WiFi conditions in real-world scenarios.

Similarly, Syrigos et al. [177] try to detect the causes of WiFi under-performance (e.g., high contention with other WiFi and non-WiFi devices, operation in low SNR region,

hidden terminal, or capture effect). To this end, they deploy a centralized WiFi network controller which collects performance metrics from connected APs (i.e., those exposed by the ath9k driver). The authors select two metrics: normalized channel access (NCA), i.e., the ratio between channel access attempts per second and the maximal channel access attempts per second as calculated with analytical 802.11 models; and frame delivery ratio (FDR), i.e., the ratio between successful transmissions per second and channel access attempts per second. The classification is preceded by data modeling and feature extraction and performed with four diverse algorithms: DT, RF, SVM, and kNN. After fine-tuning the algorithms' parameters, the authors manage to achieve a remarkable detection accuracy of 99.2% with the kNN algorithm.

Trivedi et al. [178] propose WiNetSense, a centralized sensing framework, which collects the WiFi link quality statistics (e.g., RSSI) from network devices and use this information to build the global network topology and instantaneous network health information. Furthermore, the collected data is analyzed using ML algorithms such as kNN and naive Bayes (NB). Specifically, the authors try to predict the health of wireless links and show that this knowledge can be used to trigger specific decisions regarding load balancing, smooth handovers, or dynamic power control.

An anomaly detection approach that uses self-organizing hidden Markov model map (SOHMMM) is considered in [179]. The self-organizing map is an artificial neural network that is trained through a USL process. The authors report, SOHMMM shows improved anomaly detection accuracy and sensitivity, compared to other HMM-based approaches, as tested in a simulated environment.

Morshedi and Noll [182] propose a novel ML-based approach for estimating the perceived QoS of video streaming using only 802.11-specific network performance parameters collected from AP. The study produced datasets comprising 802.11n/ac/ax specific network performance parameters in the form of mean opinion scores. Then, the datasets were used to train multiple ML algorithms and achieved a 93-99% accuracy estimating the perceived QoS classes. The authors selected the logistic model tree (LMT) as the most suitable algorithm to estimate the perceived QoS of video streaming in terms of accuracy, interpretability and computational cost criteria. Note that the generated ML model can be transferred to the WiFi AP as a lightweight script to continuously monitor the such QoS.

E. Open Challenges

While most of the presented ML-based solutions for cross-network optimization (e.g., channel allocation) feature centralized operation, we believe that distributed approaches are better suited for the unplanned and chaotic nature of WiFi deployments. Moreover, we cannot assume the existence of a centralized controller that manages co-located but separately owned WiFi networks (e.g., in typical residential WiFi deployments). Note that the potential operation of such a central controller might pose a significant privacy threat, as it might require the collection of sensitive user data (e.g., the traffic volume of individual stations). Therefore, we argue that there

is an increasing need for research in the scope of a distributed ML-based optimization scheme. Particularly, multi-agent RL-based schemes seem to be a fit, where a set of agents (e.g., one at each AP) interact and share limited information with each other to collaboratively optimize the use of wireless resources while also preserving privacy.

VI. COEXISTENCE SCENARIOS

A number of research papers address the problem of the coexistence of multiple radio access technologies (RATs) in unlicensed bands by proposing ML-based solutions (Table V). Both centralized and decentralized approaches are considered, together with both offline and online training. The proposed mechanisms appear in the following main areas:

- fair channel sharing,
- network monitoring,
- signal classification, and
- cooperative networking.

In most cases, the proposed mechanisms are based on reinforcement learning (mostly Q-learning) and deep learning (mostly CNNs). Often, ϵ -greedy policy is used for Q-learning since it allows a balance between exploration and exploitation.

The coexistence of WiFi and cellular technologies is currently a popular and attractive research area.³ These technologies are already advanced and their newest generations provide peak data rates in the order of Gbit/s. However, under coexistence scenarios in unlicensed bands (e.g., LTE-LAA), they still rely on rather primitive coexistence schemes based on energy-sensing and hence suffer from frequent collisions and significant throughput degradation of up to 90% [227], [228]. This is because these technologies are heterogeneous: they implement different MAC and PHY, they are usually managed by separate operators, and they do not natively support inter-technology communication for spectrum sharing. Therefore, fair sharing of unlicensed radio resources is a challenge [33]. Most papers propose to optimize LTE behaviour (i.e., the newcomer to the unlicensed bands) so that WiFi performance is not degraded [229]. In some cases, however, it is proposed that both technologies implement some sort of ML to improve their coexistence. Fig. 14 presents different approaches considered by researchers: from a central controller implemented for both technologies up to separate ML agents installed in LTE base stations (BSs) and WiFi APs, which independently observe the environment (i.e., perform local observation) and take actions. Note that the state of the environment depends on the joint action of all agents, which may not be aware of individual decisions. Additionally, in the reviewed papers, typically only downlink LTE transmissions are considered to interfere with either uplink or downlink WiFi transmissions, while LTE uplink traffic is considered to be scheduled in the licensed band.

³Channel sharing with other technologies is described in Section VII where, among others, we address sensor and vehicular networks. Additionally, we refer the readers to [225], in which different learning paradigms for IoT communication and computing technologies are surveyed, and to [226], in which ML-supported detection and identification of IoT devices is surveyed.

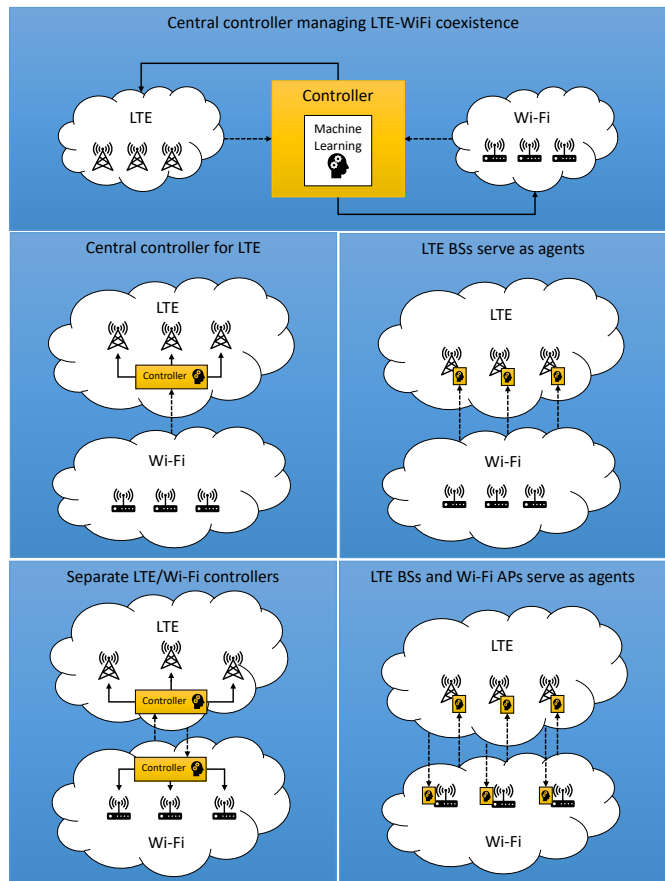

Figure 14. Types of ML implementations in LTE/WiFi coexistence scenarios. Dashed arrows represent observation, solid lines represent actions, and blue rectangles represent interference domains.

A. Fair Channel Sharing with Cellular Networks

Several papers propose to adjust LTE-unlicensed (LTE-U) behaviour, by either a central controller or by distributed learning. Their main goal is to intelligently avoid interference with incumbent technologies, like WiFi, as a solution to the problem of the negative impact of periodic LTE transmissions on channel utilization efficiency and channel access fairness [230].

Most of the papers implement Q-learning and propose modifications to the duty cycle management (DCM), being a part of the carrier sense adaptive transmission (CSAT) algorithm (cf. Fig. 15), or to the almost blank sub-frame (ABS) allocation mechanism [193], [231], which is traditionally used to avoid co-channel cross-tier interference in case of heterogeneous cellular scenarios, e.g., in scenarios composed of macro and small cells (Fig. 16). The main goal is to improve coexistence and channel sharing efficiency by intelligently disabling LTE transmissions in certain sub-frames to allow WiFi transmissions and outperform the legacy DCM.

Centralized LTE-U/WiFi channel access management is proposed in the following papers. In [205], the traffic load of each system is modeled as an M/M/1 queue and Q-learning is used by a central controller to adjust the allocation of

Table V

SUMMARY OF WORKS ON IMPROVING WIRELESS NETWORK COEXISTENCE WITH ML. PAPERS INDICATED WITH AN ASTERISK (*) IMPLEMENT WI-FI AGENTS; OTHER PAPERS DEPLOY AGENTS ONLY ON THE COMPETING TECHNOLOGY SIDE.

Area	Ref.	ML category	ML mechanisms	Year	Evaluation method
Fair channel sharing with cellular networks (Section VI-A)	[183]	RL	QL	2015	Simulation
	[184]*	RL	QL	2016	Simulation
	[185]	AL.	Markov game	2017	Simulation
	[186]	RL	QL	2017	Simulation
	[187]	RL	QL	2018	Simulation
	[188]	RL	QL	2018	Simulation
	[189]	RL	QL	2018	Simulation
	[190]	RL	QL	2018	Simulation
	[191]	RL	LSTM	2018	Simulation
	[192]	RL	QL	2018	Simulation
	[193]	DL	DRL, QL	2019	Simulation
	[194]	RL	QL	2019	Simulation
	[195]*	RL	QL	2019	Simulation
	[196]*	RL	QL	2020	Simulation
	[197]*	RL	MAB	2020	Simulation
	[198]	DL	DRL, MDP, DQN	2020	Simulation
	[199]	RL	QL	2020	Simulation
	[200]	RL	QL	2020	Simulation
	[201]	RL	QL	2020	Simulation
	[202]	DL	DRL, TRPO	2020	Simulation
[203]*	RL	clustering-based MAB	2021	Simulation	
[204]	RL	QL	2021	Simulation	
[205]*	RL	QL	2021	Simulation	
Network monitoring (Section VI-B)	[206]	RL	QL, double QL	2016	Simulation
	[207]	RL	QL	2017	Simulation
	[208]	RL	QL	2017	Simulation
	[209]	RL	fuzzy QL	2018	Simulation
	[210]*	SL	DNN, CNN, LSTM	2019	Simulation, experimental
	[211]	DL	CNN, NNMR	2020	Experimental
	[212]	SL	RF	2021	Simulation
	[213]	DL	CNN, TL	2021	Simulation, experimental
[214]	USL	NN	2021	Simulation	
Signal classification (Section VI-C)	[215]	USL	K-means clustering	2017	Experimental
	[216]	USL, SL	NN, DCNN	2020	Simulation
	[217]	DL	CNN/RNN	2020	Simulation
	[218]	SL	NN, logistic regression	2020	Simulation
	[219]	DL	CNN	2020	Simulation
	[220]	DL	CNN	2021	Simulation
Cooperative coexistence (Section VI-D)	[221]	RL	TRPO	2020	Simulation
	[222]	RL	TRPO	2020	Simulation
	[223]	RL	NN, backpropagation	2020	Simulation
	[224]	RL	NN with fuzzy logic	2020	Simulation

LTE sub-frames in the CSAT duty cycles. In [195], an inter-RAT controller implementing Q-learning is proposed, which mandates dynamic frame selection (DFS) to improve WiFi/LTE-U coexistence fairness by considering the WiFi load. In particular, it selects the optimum sub-frame configurations out of the ones defined by 3GPP. Additionally, it is used to reduce LTE-U sub-frame transmission power to limit interference to co-channel users and increase the overall channel utilization. Similar approaches are used elsewhere: in [198], where an agent controls DCM to maximize the LTE-U throughput while

protecting WiFi transmissions, based on observing WiFi traffic demands and using DRL; in [199], where a centralized RL-based DCM learns from measured interference; and in [186], where a centralized Q-learning-based mechanism of blank sub-frame allocations is proposed to improve the overall utility function (i.e., considering target WiFi throughput as well as satisfactory LTE throughput and delay).

Decentralized channel access management for LTE-U/WiFi coexistence is proposed in the following papers. In [183], Q-learning is used for distributed control of duty cycle periods

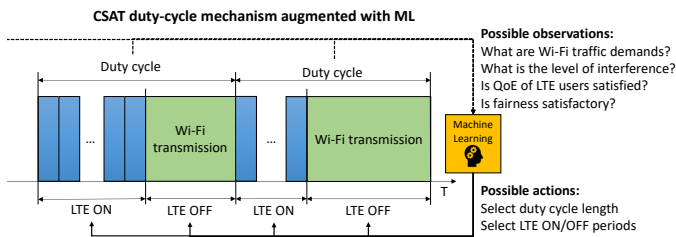

Figure 15. LTE-U CSAT coexistence mechanism. Blue rectangles represent LTE-U sub-frames of a length of 1 ms and green rectangles represent LTE-U OFF periods, during which WiFi transmissions can occur.

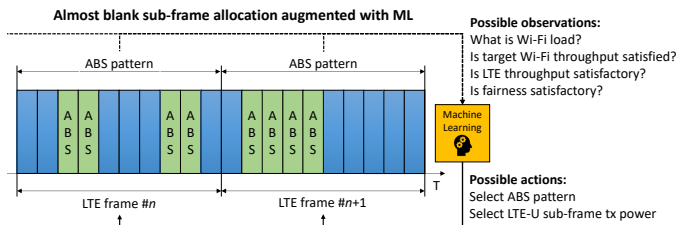

Figure 16. LTE-U ABS coexistence mechanism. Blue rectangles represent LTE-U sub-frames of a length of 1 ms and green rectangles represent ABSs, during which WiFi transmissions can occur.

by LTE-U BSs, which considers the beaconing mechanism of 802.11n. Additionally, in [189] a Q-learning based listen before talk (LBT) is proposed for LTE-U downlink transmissions which may interfere with WiFi traffic⁴. In this work, LTE-U devices are treated as secondary users that need to protect WiFi transmissions. The authors propose rewarding LTE-U users for which defer periods increase in case of increasing WiFi backoff timers (i.e., when WiFi defer periods increase). They perform simulations to show improved throughput and decreased delay of WiFi nodes in comparison to legacy LBT. WiFi system protection is also considered in [187]. The authors introduce a virtual coalition formation game (VCFG) and define the optimization problem within each virtual coalition which is composed of WiFi APs and LTE-U small base stations (SBSs) operating in the same unlicensed band. Then, (i) Kalai-Smorodinsky bargaining is used for fair time-sharing between LTE-U and WiFi and (ii) Q-learning is used for resource allocation for LTE-U. It is proposed that each SBS maximizes the sum of QoE for its users under the constraint of protecting WiFi APs. QoE is measured in terms of the mean opinion score (MOS) which is mapped to the transmission characteristics of the following applications: web browsing, file downloading, and video streaming. The authors show that this approach provides higher throughput for WiFi than standard LBT.

Lin and Yu [185] implement AL to improve coexistence fairness for LTE-U BSs. Bianchi's Markov model [233] is embedded in a sequential game to describe the contention nature of WiFi networks. Additionally, the time-slotted behaviour of LTE-U nodes is also modeled as a sequential game. These two

⁴LBT is commonly used in case of LTE-LAA, however, it was proposed in the literature also for LTE-U [232].

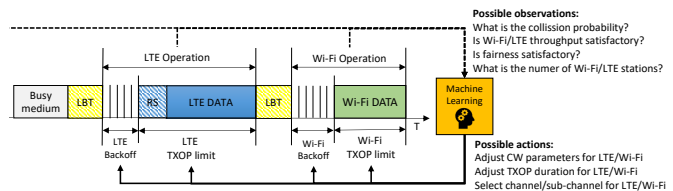

Figure 17. LTE-LAA LBT-based coexistence mechanism. RS denotes the reservation signal, which is typically used by the LTE-LAA nodes to reserve the channel until the beginning of the next frame synchronization slot.

processes are combined to form a Markov game. Each LTE-U BS serves as an agent and WiFi networks are considered the environment to which the agents adapt. Furthermore, Q-learning based multi-channel operation is proposed in [192], in which LTE-U SBSs serve as agents to allow either independent or joint optimization of duty cycles for each channel. It is shown that the proposed mechanism ensures fairness and improves throughput for multi-channel WiFi/LTE-U coexistence. Finally, in [234] LTE-U and WiFi are managed by separate SDN controllers which build decision trees. Per-technology controllers do not communicate with each other but only negotiate network sharing by playing a repeated game based on rank-order tournaments. The authors propose to use an incentive-based approach to negotiate the channel resources, i.e., there are prizes for allowing spectrum sharing and for asking the other operator for a favor. The simulation results show that it is possible to achieve harmonized coexistence of the two technologies.

Another group of papers address LTE-Licensed Assisted Access (LTE-LAA)/WiFi coexistence, which in most cases involves the adjustment of parameters of the LBT-based channel access mechanism shown in Fig. 17. Similarly to the LTE-U case, most papers are based on Q-learning.

We have found a single paper that proposes centralized channel access management for LTE-LAA/WiFi coexistence [194], in which Q-learning is used by mobile management entities (MMEs) implemented in the LTE core to adjust the LTE-LAA transmission duration to WiFi traffic intensity. Centralized collection of data regarding LTE-LAA and WiFi systems by the LTE cloud wireless access network (C-RAN) is proposed to support MMEs. Other papers implement distributed Q-learning to: (i) optimize spectral efficiency of WiFi/LTE-LAA coexistence [196], (ii) scale CW parameters depending on the collision probability observed in each backoff stage by LTE user entities (UEs), as opposed to the legacy hybrid automatic repeat request (HARQ) mechanism implemented in cellular networks [200], (iii) select optimal TXOP and muting periods (i.e., giving opportunities for WiFi transmissions) which outperform random and round-robin mechanisms [190], (iv) adjust the TXOP duration of coexisting WiFi and LTE-LAA systems based on buffered downlink data in APs and evolved Node Bs (eNBs) [184], and (v) select optimal channel and subframe numbers [204]. In [184], both WiFi and LTE-LAA nodes serve as agents, which take actions (select TXOPs from 4, 6, 8 and 10 ms) and calculate rewards based on the target occupancy ratio.

A different approach is considered in [197], where a MAB is

used to improve LTE-LAA/WiFi coexistence fairness, under the assumption of both cooperative and non-cooperative networks. In both cases, the CW sizes are optimized for the two networks by using an online training technique and either throughput or the information on LTE's ON period of the other network as rewards. Furthermore, in [188], two-level distributed learning is used. At the master level, Q-learning is used to determine the optimal LTE transmission time in the unlicensed bands using either WiFi or LTE-LAA. At the slave level, stochastic learning is used for LTE-LAA channel access with the protection of WiFi traffic. Meanwhile Challita et al. [191] propose a new type of deep learning to improve LTE-LAA coexistence with other LTE-LAA/WiFi networks. The authors combine a non-cooperative game with RL supported by the LSTM concept. It is used for modeling the self allocation of resources by LTE-LAA SBSs. In particular, dynamic channel selection, carrier aggregation, and fractional spectrum access are considered for SBSs. It is assumed that exponential backoff is used for WiFi and non-exponential backoff is used for LTE-LAA (i.e., in each epoch a static CW is assumed, adopted from one epoch to another). It is shown that this approach not only improves performance in terms of LTE rate but also in terms of reducing disturbances in WiFi's performance and achieving coexistence fairness with WiFi networks and other LTE-LAA operators. Finally, in [204], Q-learning is used for joint channel/sub-frame selection. In this work, only LTE-LAA BSs perform learning with zero knowledge of concurrent WiFi systems.

We expect that WiFi/New Radio-Unlicensed (NR-U) coexistence will gain a growing interest of the research community in the nearest future [33], [35], [235], [236]. One of the first ML-based works is [201], where Q-learning is used to adjust the timing of NR-U's ABSs to WiFi's data transmissions to achieve higher throughput and better channel utilization in comparison to static ABSs allocation. In particular, an NR-U BS serves as an agent which listens to WiFi network parameters and learns the data transmission rules of WiFi stations. Another interesting work is reported by Hirzallah and Krunch [203], who propose a clustering-based MAB real-time algorithm that runs on NR-U/WiFi nodes to adapt sensing thresholds depending on network dynamics. The authors show that sensing threshold-adaptive devices employing ML do not harm neighboring legacy devices (with fixed sensing thresholds) and that both WiFi and NR-U throughput can be improved in comparison to standard and random sensing threshold settings.

For a more a more generic coexistence setting, Yu et al. [202] address a DARPA challenge on "autonomous radios to manage the wireless spectrum." They propose a modification of DQN to adapt to wireless network behaviour. The authors show that by centralized learning (at the gateway) and distributed execution (at the nodes) it is possible to provide fairness in channel access, when coexisting with other network types (like WiFi).

B. Network Monitoring

Efficient network monitoring is a feature which can greatly support inter-technology coexistence by predicting the number of contending nodes/technologies, which then can serve as a guidance for RAT behaviour adjustment.

Yang et al. [210] propose centralized monitoring. An offline DNN-based learning from real samples is used to predict the number of competing WiFi and IoT devices in a given area. Using the inference results, the gateway (which is connected with an IEEE 802.11 AP using an Ethernet link and with IoT IEEE 802.14.5 nodes using wireless links) predicts the number of transmitting devices for each technology using a dedicated three-way handshake-based rendezvous phase on a primary channel. After that, it mandates the optimal WiFi and IoT parameters to minimize inter-technology interference, e.g., the CW for WiFi nodes, the length of the contention access phase for the IoT nodes, the assignment of the secondary channels for both technologies. Additionally, Ahmed et al. [212] install a cognitive monitoring module in each eNB to optimize LTE operation in unlicensed bands. The monitoring module is aware of the number of coexisting eNBs and APs. It uses a RF-based classifier to identify the environment state and select an appropriate scheduling and resource allocation scheme which optimizes LTE throughput without deteriorating the performance of WiFi networks. Similarly, Galanopoulos et al. [206] use centralized Q-learning and double Q-learning to improve the unlicensed spectrum utilization for carrier aggregation of LTE-Advanced (LTE-A), while providing fair coexistence with WiFi nodes. eNBs learn the channel occupation time by WiFi users and select least occupied channels. This procedure is further optimized with double Q-learning, in which LTE-A transmission power is additionally adjusted to lower the impact of LTE-A transmissions on with WiFi users.

Distributed network monitoring is proposed in [214], where the unsupervised NN-based estimation of the number of coexisting WiFi nodes is implemented in NR-U nodes. The learning process builds upon the detected transmission collision probability in the unlicensed channel. It is shown that this solution outperforms the often used Kalman filter-based solutions. Furthermore, Yang et al. [209] use fuzzy Q-learning to either centrally (central unit in C-RAN) or distributively (each eNB) learn the WiFi performance to improve the scheduling decisions on the LTE-LAA side.

There are also papers which take advantage of a dedicated interface between WiFi and LTE. In [207], [208], each LTE user obtains information from the 802.11k amendment on the load of the coexisting APs. Then, supported by Q-learning, LTE offloading decisions are made. This is interesting from the WiFi perspective, since overloaded APs are not selected by this mechanism, and therefore WiFi networks performance is not worsened by the offloading decisions.

C. Signal Classification

Machine learning is also used for signal classification and recognition without the need for implementing a dedicated interface between technologies or knowing the per-technology operation patterns. Wu et al. [31] survey wireless modulation recognition and wireless technology recognition supported by DL techniques.

Yang et al. [219] use CNNs to classify LTE-U and WiFi signals and in [220] they are used by LTE eNBs to classify WiFi conditions (saturation, non-saturation) without the need

of decoding WiFi frames, based on inter-frame space (IFS) histograms. Furthermore, in [213], CNNs are used to classify LTE and WiFi signals using an SDR-based RAT classifier. Interestingly, the authors used a well-known object detection you only look once (YOLO) model use transfer learning and speed up the training process of their classifier. The only change required was the adaption of the last (Softmax) layer to appropriately classify LTE and WiFi signals. The developed solution provides 96% accuracy of RAT recognition. Gu et al. [217] use 80,000 LTE-U/WiFi signal samples to train CNN and RNN to recognize LTE-U/WiFi signals. The RNN-based approach appeared unsatisfactory, while the CNN-based approach provided satisfactory results. Additionally, in [218], a NN with linear regression is used to track key performance indicators (KPIs) and estimate the probability of LTE-LAA/WiFi coexistence, without using knowledge of the MAC/PHY protocols and parameters of the two technologies. Furthermore, Sathya et al. [216] use ML to distinguish between the presence of one or two WiFi APs interfering with an LTE-U BS, based on detected energy levels during the OFF periods of the DCM instead of decoding WiFi frames. Finally, Pulkkinen et al. [211] analyze deep learning-based interference detection. The authors formulate, among other, the following practical recommendations to be used in future ML-based interference detection schemes: (i) deep learning-based approaches require similar levels of noise in testing and training data sets or a large number of samples with different noise levels from different environments, (ii) training should include multi-label classification. WiPlus [215] uses ML (i.e., k-means clustering) on the WiFi side to detect the LTE-U interference by using the spectral scan capabilities of COTS WiFi hardware. This allows WiFi to quantify the effective available channel airtime of each WiFi link (downlink/uplink) at runtime. Moreover, the obtained timing information about LTE-U's ON and OFF phases allow WiFi to schedule its transmissions only during the OFF phases to avoid collisions with LTE-U.

D. Cooperative Coexistence

Inter-network coexistence can also take on a cooperative form. A prominent example are WiFi-LiFi networks, where the light fidelity (LiFi) component is responsible for data transmission using light waves (the THz band). Visible light communication (VLC) has many advantages such as high bandwidth, license-free operation, and electromagnetic safety. However, it has a short range and is vulnerable to link outage caused by obstructions. Therefore, it is often paired with WiFi in the form of a hybrid network.

Wu et al. [237] provide a recent survey of research on this topic. They mention one ML-based solution related to load-balancing, done by Ahmad et al. [221], [222], where RL is used to provide centralized AP selection, to avoid servicing users by overloaded APs. In another work, Alenezi and Hamdi [238] consider the optimization of a hybrid WiFi-VLC network with centralized control and Q-learning to improve network throughput. In [223], an NN-based approach is used to select WiFi-LiFi APs to avoid frequent handovers. The handover decision is made based on channel quality, resource availability

and user mobility, e.g., WiFi-only APs are preferred for mobile users while WiFi-LiFi APs are selected for static users based on received signal strength and user satisfaction levels. Finally, in [224], fuzzy logic is combined with NN to support WiFi-LiFi handovers.

E. Open Challenges

We have identified several open challenges in the area of network coexistence. The performance of the proposed ML-based mechanisms is mostly verified by simulations. Therefore, real testbed validation can be considered as an important open challenge since it would validate the ML-based operation with real radio signals. This will help identify crucial factors which have not been implemented yet (or are impossible to be included) in the simulators and may have been overlooked by researchers. Additionally, only a few papers consider adjusting the behaviour of both WiFi and LTE nodes. In most cases only the LTE operation was supported by ML while the WiFi operation was left unchanged. With the opening of the new 6 GHz unlicensed spectrum band, which paves the way to redefine channel access rules defined for other unlicensed bands [147], [239], [240], we believe that changes in the operation of both technologies could be considered in the future. Furthermore, only several papers concentrate on the new features introduced by NR-U and none of them addresses the configuration possibilities introduced by the newest 802.11 amendments (like 802.11ax). We believe that, e.g., the coexistence of NR-U with 802.11 OFDMA/MU-MIMO channel access gives novel options to be considered by future ML-based mechanisms. Finally, following [33], [241], we strongly agree that high attention should be paid to the security of inter-technology operation, e.g., in case of augmenting coexisting networks with federated learning.

VII. MULTIHOP WI-FI NETWORKS

The primary design goal for IEEE 802.11 networks is to be a single-hop access network. However, it can also be used in a variety of multihop settings (e.g., ad hoc, mesh, sensor, vehicular) either using the mainline standard (802.11a/b/g/n/ac/ax) or a dedicated amendment (such as 802.11ah for IoT). Research papers dealing with multihop settings often either do not specify the underlying technology, assume a generic CR technology, assume heterogeneous networks (e.g., 802.11 and LTE), or use an alternative technology (which could theoretically be replaced by WiFi). One of the reasons for this is that the key multihop problem (routing) is beyond the scope of 802.11. Therefore, in the following, we provide only a brief overview of how ML can be applied in such settings with an emphasis on pointing the reader towards relevant surveys and tutorials. Indeed, an overview of using ML in multihop wireless settings could be a topic for a whole, separate survey.

A. Ad Hoc Networks

The research popularity of (generic) ad hoc networks and MANETs reached its peak over a dozen years ago. They have mostly been replaced by their more application-oriented

variants (mesh, sensor, vehicular, etc.) which we will discuss further on⁵. An overview of applying ML techniques to ad hoc networks can be found in a 2007 paper by Forster [29]. The state of the art reported in this paper is obviously outdated, but the list of applicable ML techniques (RL, swarm intelligence, mobile agents, etc.) and use cases (mainly improving routing) remains current. Al-Rawi et al. [243] provide an overview of applying RL to improve routing in distributed wireless networks. For more WiFi-related examples, we refer readers to [244]–[246] for applying Q-learning to the optimized link state routing (OLSR) routing protocol and to [247] for applying RL to 802.11-based delay tolerant networks (DTNs).

ML can also be used to optimize ad hoc network configuration [248], but this example is for a cognitive radio ad hoc network (CRAHN) (i.e., without 802.11). Another active area of research for MANETs is mobility prediction [249], but again the ML-based solutions do not explicitly consider WiFi [250], [251]. Similarly, research on applying Q-learning to interference cancellation in ad hoc networks also does not consider WiFi [252].

B. Mesh Networks

Karunaratne and Gacanin [253] provide a recent tutorial on ML approaches in WMNs. Important problems which can be solved with ML include: routing, channel assignment, and network deployment. The authors map ML techniques (such as SVM, k-means clustering, and Q-learning) to the identified WMN problems and point out future research directions (including the potential of DL).

An example of using Q-learning to help clients perform channel selection (or rather, AP selection) in an IEEE 802.11 mesh network can be found in [254]. Decisions are based on estimated collision probability and received signal strength. The authors show that the learning approach can outperform a best signal strength heuristic, especially under non-uniform node distribution.

Another example is training a NN to predict link bandwidth in an 802.11 mesh network [255]. As inputs the authors propose using the averages of important PHY and MAC metrics: SNR, transmission time, MCS, and re-transmission rate. The approach is able to accurately predict link bandwidth, which can then be used as a routing metric.

Link quality prediction is also the topic of a paper by Bote-Lorenzo et al. [256]. Based on an extensive dataset from an existing 802.11-based community WMN, they evaluated four ML algorithms for regression (online perception, on-line regression trees with options, fast incremental model trees with drift detection, and adaptive model rules). Only the first of these was able to outperform a simple baseline and only under certain circumstances. This led to the design of a hybrid algorithm, which supports the thesis that applying ML is not a straightforward approach.

For heterogeneous (WiFi and LTE) mesh networks, the routing protocol can be enhanced by Q-learning for RAT selection

⁵Ad hoc networks consisting of unmanned aerial vehicles (UAVs) are a dedicated use case, for which RL-based solutions are also being developed [242].

[257]. In this approach, each node performs observations as follows: LTE link quality is based on network load (measured through buffer occupancy), WiFi link quality – according to the current PHY transmission rate. Through appropriate RAT selection, nodes can observe up to 200% throughput increase compared to the single-technology case.

Finally, we comment on the dedicated 802.11s amendment for mesh networks. Among its features, it introduced MAC-layer routing called *path selection* in the form of the hybrid wireless mesh protocol (HWMP). However, our literature review did not identify any papers directly related to applying ML for improving the performance of either HWMP or other 802.11s functionalities. A paper on network topology inference uses external sensors and an ML approach to infer the topology of a simulated 802.11s network, but no specific mesh functionalities are considered [258]. The lack of dedicated 802.11s research is most likely the result of the limited deployment of 802.11s by the industry.

C. Sensor Networks

Applying ML to sensor networks (i.e., the communication part of IoT) is an active research topic. Some relevant surveys in this area include [25], [259]–[263]. Among the most important network performance research problems for sensor networks, which can be solved with ML methods, are: sensor grouping (clustering, data aggregation), energy-efficient operation (scheduling, duty cycling), resource allocation (cell/channel selection, channel access), traffic classification, routing, mobility prediction, power allocation, interference management, and resource discovery [261]. However, WiFi is only one of many IoT-enabling technologies and 802.11-related solutions are rarely mentioned in these surveys with the only directly performance-related work being classifying 802.11 interference using a deep convolutional neural network (DCNN) [264], [265], SVM [266], or various types of SL classifiers: classification trees (CTs) and SVM [267].

There are two 802.11 amendments related to IoT: 802.11af and 802.11ah. The former is a CR-based approach to use WiFi in TV white space spectrum. It has not enjoyed commercial success and there are also few research papers related to improving 802.11af performance with ML. A singular example is the work by Xu et al. [268], [269] on 802.11af rate adaptation schemes, which use DL models, although their work is in the context of vehicular networks.

Meanwhile, the 802.11ah amendment has had more commercial success (as HaLow) and has received more attention from the research community. However, while 802.11ah permits tree-based multihop communication, it is a predominantly single-hop technology. This is reflected in a recent survey on 802.11ah research [270] where, out of about 200 cited references, only three consider multi-hop scenarios. Also, surprisingly, only two papers by Tian et al. [271], [272] deal with applying ML: both use a form of supervised learning to optimize the parameters of 802.11ah's grouping functionality, restricted access window (RAW). A similar problem is also addressed in [273], where an MLP NN configures these parameters considering, i.e., network size and the MCS values used. Other applications of

ML to 802.11ah include: improving coexistence with 802.15.4g devices, a type of low-rate wireless personal area network (LR-WPAN), by avoiding interference with their transmissions using a Q-learning-based backoff mechanism [274], grouping sensors based on their traffic demands and channel conditions using a regression-based model [275], grouping sensors based on their data rates by classifying them with NNs [276], and improving carrier frequency offset estimation using various types of DNNs [277].

Finally, research is also being done for generic WiFi (mainline amendments). Zhao et al. [278] propose a deep Q-learning (DQL)-based method of optimizing CW for energy-constrained IoT networks. Chen et al. [279] also optimize CW but using a deep NN for IoT networks using 802.11ax. Shin et al. [280] provide a method for RAT selection, between WiFi and narrow-band IoT (NB-IoT), using RL to optimize for per-node latency. This has been further extended for mobile sensor networks incorporating UAVs. Li et al. [281] and Kurunathan et al. [282] presented a learning-based approach using DQN and DDPG, respectively, for trajectory planning.

D. Vehicular Networks

There has been much research in the area of applying ML to vehicular networks, with WiFi being only one of the many considered wireless access technologies. Some recent surveys and tutorials include [283]–[289]. They point to the application of ML in vehicular networks in the following areas of performance improvement: channel estimation, traffic flow prediction, location prediction-based scheduling and routing, network congestion control, load balancing and handovers, and resource management. Other, non-performance areas where ML can be applied include vehicle trajectory prediction (for ensuring road safety), network security, and in-car infotainment [290].

From the WiFi perspective, 802.11p is the amendment dedicated to vehicular networks and is included in larger vehicle-to-everything (V2X) frameworks such as dedicated short-range communications (DSRC) and the ETSI ITS-G5 standard [291]. A review of ML-based resource allocation approaches in DSRC networks can be found in [287]. Examples of using ML for improving 802.11p performance include: using DRL for per-link band and transmission power allocation [292], RL for tuning the CW size [293]–[295], Q-learning for improving handoff decisions [296], improving transmission control protocol (TCP) performance with federated learning [297], DNNs for channel estimation [298], and using RL for selecting the data transmission rate in a high-mobility scenario [286], [299].

An emerging future research direction is applying ML to 802.11bd, the successor to 802.11p scheduled for release in 2022 [300]. Beam alignment is one important problem of mmWave bands (cf. Section IV-A). However, contrary to WLAN scenarios, the knowledge of a vehicle's position can be used to support beam sector selection [301], where learning to rank (LTR), also referred to as machine-learned ranking (MLR), can rank antenna pointing directions. Extending the input information from just the location of the receiver to the

location of surrounding vehicles, called situational awareness, can improve performance of ML-based algorithms. Beam alignment can be determined using classifiers [302], [303] or regression models [304], [305]. The authors note that throughput can be satisfactory even if the best beam pair is not selected, providing an accuracy-overhead trade-off.

E. Relay Networks

The typical single-hop 802.11 deployment scenario can be extended to a two-hop case with *cooperative communications*, where stations are allowed to relay the transmissions of others [306]. Such functionality requires appropriate coordination between the AP and stations, which can be enhanced by designing a mechanism to support concurrent transmissions from different devices in a WLAN setting [307]. Since the AP may not have full information of the whole network, the authors model the problem as a partially observable Markov decision process (POMDP), and use an RL algorithm that is able to find which senders can transmit simultaneously. Results show that low-rate links, usually corresponding to distant stations, significantly improve their throughput. Despite this singular example, the relay network concept, for WLANs, has received limited interest from ML researchers. If relay networks become an important feature of future WiFi networks, solutions can be borrowed from 5G networks such as the ML-based relay selection of [308].

F. Open Challenges

While a multitude of ML-related open research challenges can be listed for multihop networks in general, much fewer can be named if we restrict our focus to WiFi-based multihop networks. This is on account of WiFi being predominantly used in single-hop deployments, as mentioned in the introduction to this section. Even the latest amendments dedicated to sensor (802.11ah) and vehicular (802.11bd) networks mainly operate in single-hop.

One particular area where WiFi can be used for wireless multihop transmissions is *providing FWA over mmWave links* (cf. Section IV-A). This is an important use case for 802.11ay, where coverage can be extended with a mesh-like distribution network [148]. Research is required in developing new (or adopting existing) ML-based solutions to this particular scenario in the areas of resource allocation and resource coordination. An example solution is provided by Lahsen-Cherif et al. [309] – they develop a QL-based routing protocol which optimizes energy usage and throughput in a backhaul WMN scenario with directional links, but without explicitly stating whether WiFi is used as the wireless technology.

Another area with open challenges is *relay selection for vehicular networks*. The authors of [310] suggest a cross-layer approach combining routing with the 802.11 stack. ML could be used to more accurately assess per-link routing cost. Alternatively, auxiliary sources of information could be used to support vehicular relay selection. A first example comes from Morocho-Cayamcela et al. [311], where an ML algorithm was trained to select relays based on satellite imagery. Using such imagery and other types of auxiliary information, combined

with the power of ML, can potentially improve vehicular network performance.

VIII. AVAILABLE TOOLS AND DATASETS

The reviews of research papers in the previous sections confirm that ML-based control solutions often overtake traditionally designed ones in terms of performance and efficiency. However, to reach such high performance levels, long training is required. For example, an RL agent needs many interactions with an environment to learn the best policies, while in SL, the tuning of an ML model requires access to large labelled datasets. In this section, we describe the available research tools and datasets that were used in the reviewed papers and are available for other researchers in the field.

A. Tool Chains

From our keyword analysis of more than 200 papers combining ML with WiFi, regarding the evaluation methodology, we found that most researchers run network simulations ($\approx 80\%$) to validate their solutions. Only around a quarter of them performed analytical investigations or experiments in real testbeds. The lack of real-life experiments is understandable as they are often complex, risky, and expensive to execute. From those using simulations, most often the ns-3 network simulator⁶, known from traditional networking research, was used with a share of 10%. Meanwhile, experimental studies were mostly based on SDR platforms like Ettus USRPs⁷ whereas COTS WiFi hardware, mostly with Atheros and Intel chipsets, was rarely used. The most commonly used ML libraries were Tensorflow (10%) and Keras (5%).

Based on the results of our analysis it becomes evident that the seamless support of network simulators (like ns-3) and SDR platforms for research of ML-based solutions for WiFi is of great importance. We have observed the first research frameworks which aim to simplify the integration of ML and WiFi. The general role of network simulators for bridging the gap between ML and communications systems like WiFi is discussed by Wilhelmi et al. [312]. Specifically, the authors present possible workflows for ML in networking and how to use existing tools. Among these is ns3-gym [82] – a software framework enabling the design of RL-driven solutions for communication networks. It is based on the OpenAI Gym toolkit⁸ and provides an extension to the ns-3 network simulator. With ns3-gym it is possible to use any simulated communication network (e.g., mixed WiFi and LTE) as a Gym environment so that RL agents can control the behavior of network protocols. OpenAI Gym has also been integrated with Veins [313], a popular open source vehicular networking simulator based on OMNeT++. The resulting VeinsGym [314] supports the use of ML both at the protocol as well as at the application level. Recently, Yin et al. [315] proposed ns3-ai, which offers the same functionality as ns3-gym but better performance by using shared memory for interprocess communication when running both the simulation and the Gym agent locally. GrGym [316]

is similar but it builds on the GNU Radio⁹ signal processing platform, which allows integrating any GNU Radio program as an environment in the Gym framework by exposing its state and control parameters for the agent’s learning purposes. In contrast to ns3-gym, GrGym allows the WiFi network to be a real testbed consisting of SDR nodes performing real transmissions over the air. This enables studying the performance of an ML-based solution under real channel and interference conditions. The downside is the higher effort required to setup a network as well as the lack of reproducibility. Finally, Komondor [159] is another network simulator which already supports a subset of the 802.11ax standard. It was designed for simulating complex environments in next-generation WiFi networks with direct ML support. The authors identify several use-cases and present ML-based solutions.

B. Datasets

The existence of open-source and standardized datasets is essential for training and comparing ML-based algorithms. Moreover, the existence of such datasets accelerates development and fosters reproducible research. For example, the recent advances in image classification and recognition were enabled by the emergence of such large labelled image datasets (e.g., ImageNet [317]).

We have found that researchers usually rely on their own datasets. Specifically, in 49 papers, they created labelled datasets by running experiments in testbeds and/or simulators, while only in 6 articles they used publicly available datasets. Moreover, while being a good practice, releasing the created dataset along with the published paper is still not the case for most of the publications (i.e., only 6 datasets were released). Here, we describe datasets available online that the community can immediately use for further ML-based Wi-Fi performance optimization.

CRAWDAD¹⁰ is a repository with a vast set of WiFi measurements. The datasets include traces from smartphones performing WiFi scans, multipath TCP traces collected from a WiFi campus network, as well as traces collected for other wireless technologies like Bluetooth and ZigBee. Challita et al. [191] used a subset of the CRAWDAD dataset which included records (e.g., information about the amount of transferred data, error rates, signal strength) collected by polling WiFi APs every 5 minutes in a corporate research center over several weeks. Similarly, a dataset called *sigcomm2008* contains traces of wireless network measurement collected during the SIGCOMM 2008 conference.

IEEE DataPort¹¹ is another large repository of datasets created to encourage reproducible research. Within this repository, Karmakar et al. [56] made available the IEEE 802.11ac performance dataset¹² that contains information regarding normalized throughput achieved under five link configuration parameters (i.e., channel bandwidth, MCS, guard interval, MIMO and frame aggregation) and the channel quality measured as SNR.

⁶<https://www.nsnam.org>

⁷<https://www.ettus.com>

⁸<https://gym.openai.com>

⁹<https://www.gnuradio.org>

¹⁰<http://www.crowdad.org>

¹¹<https://iee-dataport.org/>

¹²<https://iee-dataport.org/documents/ieee-80211ac-performance-dataset>

Kaggle¹³ is an online platform for data scientists and machine learning practitioners. It allows users to find and publish datasets. Moreover, it is frequently used by companies to organize competitions to solve data science challenges. At the time of writing, the Kaggle platform offers only a limited number of WiFi-related datasets, e.g., the *WiFi Study*¹⁴ dataset contains a study of the quality of the WiFi and user perceptions of WiFi conducted by students in a dormitory.

Next, we briefly describe the datasets from the reviewed papers that were made available by the researchers on their individual webpages. Herzen *et al.* [68] provided a dataset used to predict throughput based on basic performance metrics (e.g., received power, channel width) collected in a small testbed¹⁵. *Cell vs. WiFi*¹⁶ is a publicly available dataset based on an Android application that collects packet-level traces of TCP downlink and uplink traffic between a mobile device and a server for both WiFi and cellular networks. The dataset was used in [318] to find hidden dependencies in low level WiFi performance data. Polese *et al.* [112] released an experimental waveform dataset¹⁷ generated using the NI mmWave transceiver system with 60 GHz radio heads, as well as the source code using Keras API for training and testing ML models¹⁸. Similar measurement data for indoor mmWave using 802.11ad from the papers by Aggarwal *et al.* [107], [108] is also available¹⁹. Rice University’s LiveLab dataset²⁰ contains long-term measurements from real-world smartphones about their usage (e.g., CPU time) as well as data collected over a WiFi interface (e.g., periodic readings of available WiFi access points). The dataset was used in [319].

The available datasets provide mostly raw measurements (e.g., RSSI, CSI) or traces of sniffed WiFi traffic which can be used to find anomalies with ML techniques. For example, Fulara *et al.* [320] tried to detect causes of unnecessary active scanning performed by WiFi stations. Moreover, there exist datasets meant for WiFi-based applications (e.g., human detection, activity recognition, people tracing, traffic classification) which rely on ML. We believe that those datasets can be also used to improve the performance of WiFi networks. For example, if an AP knows that a traffic flow is a long-lived flow (e.g., a video transmission) it might perform some long-term optimizations to improve the flow quality that would not make sense in the case of a short-lived flow. Also, the location tracking of WiFi stations can help a WiFi network prepare for a handover operation in advance, which would result in faster handover execution and a smaller number of outage events. Example datasets containing location information and WiFi signal strength are available on the Kaggle platform²¹.

Finally, we believe that significant efforts have to be taken to create large and high-quality datasets and encourage sharing

them among the wireless research community. To this end, it would be beneficial to create standardized procedures for data collection to allow researchers to cooperatively build new and extend existing datasets. The potential use of different wireless platforms/testbeds for measurements might positively impact learning performance (e.g., avoid model over-fitting). Due to diverse hardware characteristics (such as TX power), however, the created datasets have to be precisely described (i.e., provided with complete metadata) to avoid misunderstanding and unnecessary debugging of the ML models.

IX. FUTURE RESEARCH DIRECTIONS

Through all of the previous sections, we have overviewed, discussed, and systematically classified many research works aiming to improve WiFi through machine learning. All these works have a similar motivation: the use of ML to find what are the best decisions that a WiFi network, or its different functionalities, can make to offer better performance in constantly changing and heterogeneous scenarios. Although we covered over 200 papers, they represent only the first step of a long path towards fully adopting ML in future WiFi and wireless networks in general. In the following, we describe several general open challenges and suggest potential future research directions.

A. Dealing with New and Flexible but Complex WiFi Features

In recent years, the catalogue of available WiFi functionalities has been rapidly expanding to include more complex features to cope with current and expected user needs. For example, IEEE 802.11be will incorporate multi-link operation and, possibly, multi-AP coordination in addition to already existing features such as OFDMA, downlink and uplink MU-MIMO, spatial reuse, and channel aggregation. A common aspect of most of these functionalities is that they offer a high degree of flexibility to schedule traffic in time, space, and frequency, which, if properly used, may enable high-performance gains.

To achieve this goal, ML techniques may play an important role, enabling self-adaptation to different situations and scenarios, as well as improving decision making by leveraging past information to predict which actions will perform the best. For example, multi-band WiFi devices can use ML methods to predict link quality and select links accordingly [5].

B. Joint Optimization of WiFi Features

Most of the discussed papers focus on the optimization of a single WiFi feature like the CW of WiFi’s channel access function. However, it becomes clear that separate WiFi features cannot be optimized in isolation. Instead they must be jointly optimized with others to achieve the best possible performance. As an example consider the tuning of transmit power and carrier sensing threshold. Hence, the research on ML schemes suitable for joint optimization of multiple WiFi features is a promising future research direction. Especially developing ML solutions with a fast learning speed are of great importance due to the high complexity involved.

¹³<https://www.kaggle.com/>

¹⁴<https://www.kaggle.com/mlomuscio/wifi-study>

¹⁵<http://www.hrzn.ch/data/lw-data.zip>

¹⁶<http://web.mit.edu/cell-vs-wifi/>

¹⁷<http://hdl.handle.net/2047/D20409451>

¹⁸<https://github.com/wineslab/deepbeam>

¹⁹<http://bit.ly/60ghz-link-adaptation>

²⁰<http://livelab.recg.rice.edu/traces.html>

²¹<https://www.kaggle.com/c/indoor-location-navigation/>

C. ML-enhanced WiFi Features by Design

Most of the discussed works build ML functionalities on top of current WiFi features, interacting with them by tuning their parameters. An open challenge and a disruptive future approach would be to re-design these functionalities by explicitly embedding ML capabilities in them. Heuristic algorithms or hard-coded rules could be replaced by ML agents able to self-configure based on gathered experience [80], [321]. For example, in spatial reuse, the transmission power is adjusted following a set of predefined rules and this may unnecessarily limit the achievable throughput in some scenarios. Providing guaranteed QoS is another challenge for future WiFi networks which could benefit from being designed with built-in ML capabilities [5].

D. ML-based Architectures and Standardized Interfaces

Another open challenge to solve is where to perform and execute certain ML-related actions, which in the case of WiFi networks may include the device, the AP, a controller in the network edge, and a controller in the cloud. In any case, the answer to this question requires knowing aspects such as the tolerable latency required to obtain the output of an ML process, the available information to perform it, and the computational resources. The design and orchestration of distributed ML solutions that adapt to the pros and cons of each case is still an open challenge, requiring the definition of new interfaces as well as how and when to exchange data and ML models between components.

A pioneering work dealing with these aspects for WLANs is [322], where the International Telecommunications Union (ITU) unified architecture for 5G and beyond is extended to support ML techniques at multiple levels, from the end device to the cloud. The work in [322] is complemented with [312], where the ‘sandbox’ element of the ITU-T architecture to execute off-line training and validation of ML techniques and models is further analyzed and discussed.

E. Set of Reference Evaluation Scenarios and Performance Metrics

Almost all published papers considering ML techniques conclude they can significantly improve system performance. While we do not question these results, we simply point out the lack of a set of common scenarios, which prevents the comparison of the results between different papers, and therefore makes it challenging to extract solid conclusions and to track the progress in the area of using ML for WiFi. Designing these scenarios in a way so they are useful to test ML solutions is challenging. Specifically, the evaluation scenarios should cover a wide range of difficulty levels. For example, in the beginning, training phases, small stationary scenarios can be helpful to illustrate and debug how ML solutions work. However, later on, the environment dynamics should be also taken into account, as they must be complex enough to include non-straightforward situations. Specifically, successful ML-based proposals should be tested in large, heterogeneous and dynamic scenarios to show that they properly adapt and scale to different conditions.

Additionally, the use of a set of common scenarios will foster another open challenge: to perform reproducible research. This is an important aspect, and also a significant open challenge, due to the amount of information required to reproduce exactly, step by step, the same environmental conditions and ML process responses in different places. The use of detailed and accurate datasets may contribute to making this possible.

F. ML-enhanced Network Simulation Tools

The development and maintenance of reference scenarios is much easier with a set of standardized and commonly accepted by the research community simulation frameworks. However, there is still a lack of such tools, which would allow seamless integration of ML solutions. Although there have been some attempts to solve the situation (e.g., the OpenAI module for ns-3 [82] and Komondor [159]), we are still far from a point where general networking simulators will allow including ML routines by default. To reach this point will be challenging, as we need to (i) define standard interfaces between WiFi components and ML functions and (ii) model the execution times required by ML instances in terms of the virtual simulation time.

G. Testbeds and Real Pilots

The previous discussion regarding the need for scenarios and suitable simulators can be directly extended to the need for testing the correct operation of ML-enhanced functionalities in real networks, not only to validate their correct operation, but also to run experiments in conditions that simulators may not be able to reproduce accurately. Therefore, the development of platforms and testbeds that support experimental research of WiFi-enhanced ML networks is a crucial aspect before deploying these solutions in real networks. An important aspect to consider, and which should be included in the design of ML-aware solutions, is that they will have to coexist with non-ML enabled solutions, and so potentially negative interactions should be considered in advance.

H. Risks of ML Uncertainty

Following the previous points, it is important to explicitly tackle situations in which the use of ML techniques causes unpredictable performance, and may compromise the correct operation of a certain feature or even the whole WiFi network. An open challenge is to design robust ML solutions that may sacrifice performance in general to prevent unexpected behaviours in particular scenarios.

ML-based models are highly successful and provide superb performance in many complex tasks, however, so far they are applied in a *black-box* manner, i.e., no information is provided about what exactly makes them arrive at their decisions. This lack of transparency can be a major drawback and might remain a limiting factor for the broad adoption of ML-based algorithms in the area of wireless network control. Specifically, giving up human control to an *intelligent black-box* brings the risk of improper behaviour or unsafe decisions that might be dangerous for the operation of wireless networks, which in many cases may be considered critical infrastructure. In recent years,

research on explaining and interpreting deep learning models attracted increasing attention: the work of Samek and Müller [323] targets validation of agent behaviour and establishing guarantees that they will continue to perform as expected when deployed in a real-world environment. Furthermore, due to explaining the internal structures, researchers hope to learn from ML-based agents capable of learning patterns that are not tractable by humans. To conclude, the explainability of ML agents will be of significant importance for the verification and certification (i.e., checking compliance with regulations) of ML-based wireless network control systems.

I. New ML Models and Distributed Learning

Finally, the last but obvious open challenge is the need to consider recent advances in ML techniques, which will certainly go together with the definition of new ML-based architectures and WiFi features. For instance, due to its recent introduction, there are still few papers considering federated learning (FL) models for WiFi. FL is a distributed machine learning paradigm where a set of nodes cooperatively train a ML learning model with the help of a centralized server and without the need to share their local data [324]. Specifically, nodes train their own local model based on local (on-device) data, and then send the model parameters to the server, which in turn merges parameters from different nodes and sends the combined (global) parameters back to the distributed nodes. We expect that FL will be of paramount importance for the optimization of WiFi networks, as it allows training models with individual data (e.g., available at stations or at the AP) while also preserving user privacy.

Transfer learning (TL) is another concept that might be helpful for wireless networks in general. It is an ML method where a model trained on one task is re-purposed on a second, related task. Usually, some re-training is required to fine-tune the model towards the second task. However, TL often allows saving time or obtain better performance in comparison to the development of a model from scratch [325]. This technique works only if the model features learned from the first task are general. In the context of wireless networks, TL might be applicable when reusing models trained in networks of a different technology (e.g., interference recognition in LTE) to boost the performance of WiFi networks.

X. CONCLUSION

ML is playing an increasing role in the field of improving WiFi performance. This survey has presented a comprehensive overview of over 200 recent ML-based solutions for a variety of performance areas. We started with basic WiFi features (such as channel access and rate adaptation), then we moved to more complex aspects (such as channel bonding, multi-band operation, and network management) and the problem of coexistence with other network technologies in shared bands. Next, we gave a brief overview of the application of ML to multi-hop WiFi settings. Finally, we summarized the tools and data sets available for researchers in this field. To the best of our knowledge, this is the first such survey to focus solely on

WiFi networks and to provide a detailed analysis of different WiFi aspects that can be supported through ML.

Revisiting Fig. 2, our analysis shows that supervised learning is often used for data classification while reinforcement learning and deep learning – for parameter optimization; unsupervised learning is less frequently used in general. Meanwhile, the most often used ML mechanisms are: Q-learning, multi-armed bandit, as well as different kinds of neural networks (ANN, DNN, and CNN). In most cases they were implemented to optimize only a constrained set of 802.11 parameters. Additionally, from reviewing the comparative Tables II to V, we observe that with the increase in computing power, DL methods are gaining in popularity.

We believe that, as a next step, researchers will try to identify ML schemes for the joint optimization of a wider ranges of WiFi features. Additionally, they should investigate the coexistence of ML-controlled and legacy networks, since it poses a possible source of unfairness in channel access. We also expect that the attractiveness of this area of research will continue to grow. To support this statement, we have identified a number of open research directions which could serve as a guide for researchers in their future work.

APPENDIX A LIST OF ACRONYMS

5G	fifth-generation mobile networks
6G	sixth-generation mobile networks
A-MPDU	aggregated MAC protocol data unit
A-MSDU	aggregated MAC service data unit
ABP	adaptation-based programming
ABS	almost blank sub-frame
AC	access category
ACK	acknowledgment
AI	artificial intelligence
AIFS	arbitration inter-frame space
AL	adaptive learning
ANN	artificial neural network
AP	access point
ARF	auto rate fallback
ARMA	autoregressive moving average
BS	base station
BSS	basic service set
CARA	collision-aware rate adaptation
CCA	clear channel assessment
CDF	cumulative density function
CFO	carrier frequency offset
CNN	convolutional neural network
COSB	channel observation-based scaled backoff
COTS	commercial off-the-shelf
CR	cognitive radio
CRAHN	cognitive radio ad hoc network
CRN	cognitive radio network
CSAT	carrier sense adaptive transmission
CSI	channel state information
CT	classification tree
CW	contention window

DBCA	dynamic bandwidth channel access	LTR	learning to rank
DCB	on-demand channel bonding	M2M	machine to machine
DCF	distributed coordination function	MAB	multi-armed bandit
DCM	duty cycle management	MAC	medium access control
DCNN	deep convolutional neural network	MADDPG	multi-agent deep deterministic policy gradient
DDPG	deep deterministic policy gradient	MANET	mobile ad hoc network
DDQN	double deep Q-network	MCS	modulation and coding scheme
DFS	dynamic frame selection	MDP	Markov decision process
DL	deep learning	MEC	multi-access edge computing
DNN	deep neural network	MFNN	multi-layer feed-forward neural network
DPP	determinantal point process	MH-GAN	Metropolis-Hastings generative adversarial network
DQL	deep Q-learning	MHCP	Matérn hard-core processes
DQN	deep Q-network	MIMO	multiple-input multiple-output
DRL	deep reinforcement learning	ML	machine learning
DSRC	dedicated short-range communications	MLP	multilayer perceptrons
DT	decision tree	MLR	machine-learned ranking
DTN	delay tolerant network	MME	mobile management entities
EDCA	enhanced distributed channel access	mmWave	millimeter wave
EIED	exponential-increase exponential-decrease	MOS	mean opinion score
EM	expectation maximization	MRL	multi-resolution learning
EMA	expectation modification algorithm	MSE	mean square error
eNB	evolved Node B	MTL	multi-task learning
FCS	frame check sequence	MU-MIMO	multi-user MIMO
FDR	frame delivery ratio	MUSE	MU-MIMO user selection
FER	frame error rate	NACK	negative acknowledgment
FFNN	feed forward neural network	NB	naive Bayes
FL	federated learning	NB-IoT	narrow-band IoT
FWA	fixed wireless access	NCA	normalized channel access
GBRT	gradient boosted regression tree	NFV	network functions virtualization
GCN	graph convolutional networks	NLoS	non-line of sight
GNA	Girvan-Newman algorithm	NN	neural network
GNN	graph neural networks	NR-U	New Radio-Unlicensed
HA-DBCA	hybrid adaptive DBCA	OFDMA	orthogonal frequency-division multiple access
HARQ	hybrid automatic repeat request	OLS	ordinary least squares
HetNet	heterogeneous network	OLSR	optimized link state routing
HMM	hidden Markov model	PDS	post-decision state-based
HWMP	hybrid wireless mesh protocol	PHY	physical
IDS	intrusion detection system	PNN	probabilistic neural network
IoT	Internet of things	POMDP	partially observable Markov decision process
iQRA	intelligent Q-learning based resource allocation	QL	Q-learning
ITE	iterative trial and error	QNN	Q neural network
ITU	International Telecommunications Union	QoE	quality of experience
kNN	k-nearest neighbor	QoS	quality of service
KPI	key performance indicator	RAT	radio access technologies
LASSO	least absolute shrinkage and selection operator	RAW	restricted access window
LBT	listen before talk	REPT	reduced error pruning tree
LiBRA	learning-based beam and rate adaptation	RF	random forest
LiFi	light fidelity	RFR	random forest regressor
LMT	logistic model tree	RL	reinforcement learning
LoS	line of sight	RNN	recurrent neural network
LPA	label propagation algorithm	RSSI	received signal strength indicator
LPWAN	low-power wide area network	RTS	request to send
LR-WPAN	low-rate wireless personal area network	RU	resource unit
LSTM	long short-term memory	SAP	spatial adaptive play
LTE	Long Term Evolution	SARA	stochastic automata rate adaptation
LTE-A	LTE-Advanced	SARSA	state action reward state action
LTE-LAA	LTE-Licensed Assisted Access	SBCA	static bandwidth channel access
LTE-U	LTE-unlicensed		

SBS	small base station
SD-WLAN	software-defined WLAN
SDN	software-defined networking
SDR	software-defined radio
SGI	short guard interval
SL	supervised learning
SNR	signal to noise ratio
SOHMMM	self-organizing hidden Markov model map
SR	spatial reuse
SS	spatial stream
STA	station
SVM	support vector machine
SVR	support vector regressor
TCP	transmission control protocol
TL	transfer learning
TS	Thompson sampling
TXOP	transmission opportunity
UAV	unmanned aerial vehicle
UCB	upper confidence bound
UE	user entity
USL	unsupervised learning
V2X	vehicle-to-everything
VANET	vehicular ad hoc network
VCFG	virtual coalition formation game
VLC	visible light communication
WARP	wireless open access research platform
WLAN	wireless local area network
WMN	wireless mesh network
WSN	wireless sensor network
YOLO	you only look once

REFERENCES

- [1] "Visual Networking Index: Forecast and Trends, 2017–2022," Cisco, Tech. Rep., 2018.
- [2] E. Khorov, A. Kiryanov, A. Lyakhov, and G. Bianchi, "A Tutorial on IEEE 802.11ax High Efficiency WLANs," *IEEE Communications Surveys & Tutorials*, vol. 21, no. 1, pp. 197–216, 2019.
- [3] B. Bellalta, "IEEE 802.11ax: High-efficiency WLANs," *IEEE Wireless Communications*, vol. 23, no. 1, pp. 38–46, Feb. 2016.
- [4] M. S. Afaqui, E. Garcia-Villegas, and E. Lopez-Aguilera, "IEEE 802.11ax: Challenges and requirements for future high efficiency WiFi," *IEEE Wireless Communications*, vol. 24, no. 3, pp. 130–137, 2016.
- [5] C. Deng, X. Fang, X. Han, X. Wang, L. Yan, R. He, Y. Long, and Y. Guo, "IEEE 802.11be Wi-Fi 7: New challenges and opportunities," *IEEE Communications Surveys & Tutorials*, vol. 22, no. 4, pp. 2136–2166, 2020.
- [6] E. Khorov, I. Levitsky, and I. F. Akyildiz, "Current Status and Directions of IEEE 802.11be, the Future Wi-Fi 7," *IEEE Access*, vol. 8, pp. 88 664–88 688, May 2020.
- [7] A. Garcia-Rodriguez, D. López-Pérez, L. Galati-Giordano, and G. Geraci, "IEEE 802.11be: Wi-Fi 7 Strikes Back," *IEEE Communications Magazine*, vol. 59, no. 4, pp. 102–108, 2021.
- [8] F. Wilhelmi, S. Barrachina-Muñoz, C. Cano, I. Selinis, and B. Bellalta, "Spatial Reuse in IEEE 802.11ax WLANs," *Computer Communications*, vol. 170, pp. 65–83, Mar. 2021.
- [9] J. Wang, C. Jiang, H. Zhang, Y. Ren, K.-C. Chen, and L. Hanzo, "Thirty Years of Machine Learning: The Road to Pareto-Optimal Wireless Networks," *IEEE Communications Surveys & Tutorials*, vol. 22, no. 3, pp. 1472–1514, 2020.
- [10] Y. Sun, M. Peng, Y. Zhou, Y. Huang, and S. Mao, "Application of Machine Learning in Wireless Networks: Key Techniques and Open Issues," *IEEE Communications Surveys & Tutorials*, vol. 21, no. 4, pp. 3072–3108, 2019.
- [11] M. Kulin, T. Kazaz, E. De Poorter, and I. Moerman, "A Survey on Machine Learning-Based Performance Improvement of Wireless Networks: PHY, MAC and Network Layer," *Electronics*, vol. 10, no. 3, 2021.
- [12] N. C. Luong, D. T. Hoang, S. Gong, D. Niyato, P. Wang, Y.-C. Liang, and D. I. Kim, "Applications of deep reinforcement learning in communications and networking: A survey," *IEEE Communications Surveys & Tutorials*, vol. 21, no. 4, pp. 3133–3174, 2019.
- [13] C. Zhang, P. Patras, and H. Haddadi, "Deep Learning in Mobile and Wireless Networking: A Survey," *IEEE Communications Surveys & Tutorials*, vol. 21, no. 3, pp. 2224–2287, 2019.
- [14] J. Kuntho, A. Karkar, S. Al-Maadeed, and A. Al-Ali, "Indoor positioning and wayfinding systems: a survey," *Human-centric Computing and Information Sciences*, vol. 10, no. 1, p. 18, May 2020.
- [15] M. Nivaashini and P. Thangaraj, "Computational intelligence techniques for automatic detection of Wi-Fi attacks in wireless IoT networks," *Wireless Networks*, vol. 27, no. 4, pp. 2761–2784, May 2021.
- [16] B. Kitchenham and S. Charters, "Guidelines for performing Systematic Literature Reviews in Software Engineering," Tech. Rep., 2007.
- [17] D. S. V. Medeiros, H. N. Cunha Neto, M. A. Lopez, L. C. S. Magalhães, N. C. Fernandes, A. B. Vieira, E. F. Silva, and D. M. F. Mattos, "A survey on data analysis on large-Scale wireless networks: online stream processing, trends, and challenges," *Journal of Internet Services and Applications*, vol. 11, no. 1, p. 6, Oct. 2020.
- [18] M. Morshedi and J. Noll, "A Survey on Prediction of PQoS Using Machine Learning on Wi-Fi Networks," in *2020 International Conference on Advanced Technologies for Communications (ATC)*, ISSN: 2162-1039, Oct. 2020, pp. 5–11.
- [19] M. Sattarian, J. Rezazadeh, R. Farahbakhsh, and A. Bagheri, "Indoor navigation systems based on data mining techniques in internet of things: a survey," *Wireless Networks*, vol. 25, no. 3, pp. 1385–1402, Apr. 2019. (visited on 01/27/2021).
- [20] W. Liu, Q. Cheng, Z. Deng, H. Chen, X. Fu, X. Zheng, S. Zheng, C. Chen, and S. Wang, "Survey on CSI-based Indoor Positioning Systems and Recent Advances," in *2019 International Conference on Indoor Positioning and Indoor Navigation (IPIN)*, ISSN: 2471-917X, Sep. 2019, pp. 1–8.
- [21] G. Oguntala, R. Abd-Alhameed, S. Jones, J. Noras, M. Patwary, and J. Rodriguez, "Indoor location identification technologies for real-time IoT-based applications: An inclusive survey," *Computer Science Review*, vol. 30, pp. 55–79, Nov. 2018.
- [22] S. Yousefi, H. Narui, S. Dayal, S. Ermon, and S. Valaee, "A Survey on Behavior Recognition Using WiFi Channel State Information," *IEEE Communications Magazine*, vol. 55, no. 10, pp. 98–104, Oct. 2017.
- [23] C. Koliass, G. Kambourakis, A. Stavrou, and S. Gritzalis, "Intrusion detection in 802.11 networks: empirical evaluation of threats and a public dataset," *IEEE Communications Surveys & Tutorials*, vol. 18, no. 1, pp. 184–208, 2016.
- [24] I. Ahmad, S. Shahabuddin, H. Malik, E. Harjula, T. Leppänen, L. Lovén, A. Anttonen, A. H. Sodhro, M. Mahtab Alam, M. Juntti, A. Ylä-Jääski, T. Sauter, A. Gurtov, M. Ylianttila, and J. Riekkii, "Machine Learning Meets Communication Networks: Current Trends and Future Challenges," *IEEE Access*, vol. 8, pp. 223 418–223 460, 2020.
- [25] M. A. Alsheikh, S. Lin, D. Niyato, and H.-P. Tan, "Machine Learning in Wireless Sensor Networks: Algorithms, Strategies, and Applications," *IEEE Communications Surveys & Tutorials*, vol. 16, no. 4, pp. 1996–2018, 2014.
- [26] M. Bkassiny, Y. Li, and S. K. Jayaweera, "A Survey on Machine-Learning Techniques in Cognitive Radios," *IEEE Communications Surveys & Tutorials*, vol. 15, no. 3, pp. 1136–1159, 2013.
- [27] L. Gavrilovska, V. Atanasovski, I. Macaluso, and L. A. DaSilva, "Learning and Reasoning in Cognitive Radio Networks," *IEEE Communications Surveys & Tutorials*, vol. 15, no. 4, pp. 1761–1777, 2013.
- [28] A. He, K. K. Bae, T. R. Newman, J. Gaeddert, K. Kim, R. Menon, L. Morales-Tirado, J. Neel, Y. Zhao, J. H. Reed, and W. H. Tranter, "A Survey of Artificial Intelligence for Cognitive Radios," *IEEE Transactions on Vehicular Technology*, vol. 59, no. 4, pp. 1578–1592, 2010.
- [29] A. Forster, "Machine Learning Techniques Applied to Wireless Ad-Hoc Networks: Guide and Survey," in *2007 3rd International Conference on Intelligent Sensors, Sensor Networks and Information*, 2007, pp. 365–370.

- [30] J. Moysen and L. Giupponi, "From 4G to 5G: Self-organized network management meets machine learning," *Computer Communications*, vol. 129, pp. 248–268, 2018.
- [31] H. Wu, Z. Han, K. Wolter, Y. Zhao, and H. Ko, *Deep Learning Driven Wireless Communications and Mobile Computing*, Publisher: Hindawi, Apr. 2019.
- [32] A. M. Mamadou, J. Toussaint, and G. Chalhoub, "Survey on wireless networks coexistence: resource sharing in the 5G era," *Mobile Networks and Applications*, vol. 25, no. 5, pp. 1749–1764, 2020.
- [33] G. Gür, "Expansive networks: Exploiting spectrum sharing for capacity boost and 6G vision," *Journal of Communications and Networks*, vol. 22, no. 6, pp. 444–454, 2020.
- [34] R. Bajracharya, R. Shrestha, and H. Jung, "Future is unlicensed: Private 5G unlicensed network for connecting industries of future," *Sensors*, vol. 20, no. 10, p. 2774, 2020.
- [35] S. Bayhan, G. Gür, and A. Zubow, "The Future is Unlicensed: Coexistence in the Unlicensed Spectrum for 5G," arXiv, cs.NI 1801.04964, Jan. 2018.
- [36] P. Zhu, J. Pinto, T. Nguyen, and A. Fern, "Achieving Quality of Service with Adaptation-based Programming for Medium Access Protocols," in *2012 IEEE Global Communications Conference (GLOBECOM)*, ISSN: 1930-529X, Dec. 2012, pp. 1932–1937.
- [37] S. Amuru, Y. Xiao, M. v. d. Schaar, and R. M. Buehrer, "To Send or Not to Send - Learning MAC Contention," in *2015 IEEE Global Communications Conference (GLOBECOM)*, Dec. 2015, pp. 1–6.
- [38] A. H. Y. Abyaneh, M. Hirzallah, and M. Krunz, "Intelligent-CW: AI-based Framework for Controlling Contention Window in WLANs," in *2019 IEEE International Symposium on Dynamic Spectrum Access Networks (DySPAN)*, 2019, pp. 1–10.
- [39] R. Ali, N. Shahin, Y. B. Zikria, B. Kim, and S. W. Kim, "Deep Reinforcement Learning Paradigm for Performance Optimization of Channel Observation-Based MAC Protocols in Dense WLANs," *IEEE Access*, vol. 7, pp. 3500–3511, 2019.
- [40] Y. Edalat and K. Obraczka, "Dynamically Tuning IEEE 802.11's Contention Window Using Machine Learning," in *Proceedings of the 22nd International ACM Conference on Modeling, Analysis and Simulation of Wireless and Mobile Systems*, ser. MSWIM '19, New York, NY, USA: Association for Computing Machinery, Nov. 2019, pp. 19–26.
- [41] C. K. Lee and S. H. Rhee, "Collision Avoidance in IEEE 802.11 DCF using a Reinforcement Learning Method," in *2020 International Conference on Information and Communication Technology Convergence (ICTC)*, ISSN: 2162-1233, Oct. 2020, pp. 898–901.
- [42] R. Ali, A. Nauman, Y. B. Zikria, B.-S. Kim, and S. W. Kim, "Performance optimization of QoS-supported dense WLANs using machine-learning-enabled enhanced distributed channel access (MEDCA) mechanism," *Neural Computing and Applications*, vol. 32, no. 17, pp. 13 107–13 115, Sep. 2020.
- [43] E. Coronado, J. Villalón, and A. Garrido, "Improvements to Multimedia Content Delivery over IEEE 802.11 Networks," in *NOMS 2020 - 2020 IEEE/IFIP Network Operations and Management Symposium*, ISSN: 2374-9709, Apr. 2020, pp. 1–6.
- [44] Y. Kihira, Y. Koda, K. Yamamoto, T. Nishio, and M. Morikura, "Adversarial Reinforcement Learning-based Robust Access Point Coordination Against Uncoordinated Interference," in *2020 IEEE 92nd Vehicular Technology Conference (VTC2020-Fall)*, IEEE, 2020, pp. 1–5.
- [45] A. Kumar, G. Verma, C. Rao, A. Swami, and S. Segarra, "Adaptive Contention Window Design Using Deep Q-Learning," in *ICASSP 2021 - 2021 IEEE International Conference on Acoustics, Speech and Signal Processing (ICASSP)*, 2021, pp. 4950–4954.
- [46] W. Wydmański and S. Szott, "Contention Window Optimization in IEEE 802.11ax Networks with Deep Reinforcement Learning," in *2021 IEEE Wireless Communications and Networking Conference (WCNC)*, 2021, pp. 1–6.
- [47] R. Ali, Y. B. Zikria, S. Garg, A. K. Bashir, M. S. Obaidat, and H. S. Kim, "A Federated Reinforcement Learning Framework for Incumbent Technologies in Beyond 5G Networks," *IEEE Network*, vol. 35, no. 4, pp. 152–159, 2021.
- [48] L. Zhang, H. Yin, Z. Zhou, S. Roy, and Y. Sun, "Enhancing WiFi Multiple Access Performance with Federated Deep Reinforcement Learning," in *2020 IEEE 92nd Vehicular Technology Conference (VTC2020-Fall)*, 2020, pp. 1–6.
- [49] T. Joshi, D. Ahuja, D. Singh, and D. P. Agrawal, "SARA: Stochastic Automata Rate Adaptation for IEEE 802.11 Networks," *IEEE Transactions on Parallel and Distributed Systems*, vol. 19, no. 11, pp. 1579–1590, 2008.
- [50] O. Puñal, H. Zhang, and J. Gross, "RFRA: Random Forests Rate Adaptation for Vehicular Networks," in *2013 IEEE 14th International Symposium on "A World of Wireless, Mobile and Multimedia Networks" (WoWMoM)*, 2013, pp. 1–10.
- [51] C. Wang, "Dynamic ARF for throughput improvement in 802.11 WLAN via a machine-learning approach," *Journal of Network and Computer Applications*, vol. 36, no. 2, pp. 667–676, 2013.
- [52] R. Karmakar, S. Chattopadhyay, and S. Chakraborty, "Dynamic Link Adaptation in IEEE 802.11ac: A Distributed Learning Based Approach," in *2016 IEEE 41st Conference on Local Computer Networks (LCN)*, 2016, pp. 87–94.
- [53] E. Kurniawan, P. H. Tan, S. Sun, and Y. Wang, "Machine Learning-based Channel-Type Identification for IEEE 802.11ac Link Adaptation," in *2018 24th Asia-Pacific Conference on Communications (APCC)*, 2018, pp. 51–56.
- [54] C.-Y. Li, S.-C. Chen, C.-T. Kuo, and C.-H. Chiu, "Practical Machine Learning-Based Rate Adaptation Solution for Wi-Fi NICs: IEEE 802.11ac as a Case Study," *IEEE Transactions on Vehicular Technology*, vol. 69, no. 9, pp. 10 264–10 277, Sep. 2020.
- [55] R. Karmakar, "Online Learning-Based Energy-Efficient Frame Aggregation in High Throughput WLANs," *IEEE Communications Letters*, vol. 23, no. 4, pp. 712–715, 2019.
- [56] R. Karmakar, S. Chattopadhyay, and S. Chakraborty, "A Deep Probabilistic Control Machinery for Auto-Configuration of WiFi Link Parameters," *IEEE Transactions on Wireless Communications*, vol. 19, no. 12, pp. 8330–8340, 2020.
- [57] R. Karmakar, S. De, A. Ghosh, T. Adhikari, and P. Jain, "S2-GI: Intelligent Selection of Guard Interval in High Throughput WLANs," in *2020 11th International Conference on Computing, Communication and Networking Technologies (ICCCNT)*, 2020, pp. 1–7.
- [58] S. Cho, "Reinforcement Learning for Rate Adaptation in CSMA/CA Wireless Networks," in *Advances in Computer Science and Ubiquitous Computing*, J. J. Park, S. J. Fong, Y. Pan, and Y. Sung, Eds., Singapore: Springer Singapore, 2021, pp. 175–181.
- [59] S.-C. Chen, C.-Y. Li, and C.-H. Chiu, "An Experience Driven Design for IEEE 802.11ac Rate Adaptation based on Reinforcement Learning," in *IEEE INFOCOM 2021 - IEEE Conference on Computer Communications*, 2021, pp. 1–10.
- [60] P. Lin and T. Lin, "Machine-Learning-Based Adaptive Approach for Frame-Size Optimization in Wireless LAN Environments," *IEEE Transactions on Vehicular Technology*, vol. 58, no. 9, pp. 5060–5073, 2009.
- [61] E. Coronado, A. Thomas, and R. Riggio, "Adaptive ML-Based Frame Length Optimisation in Enterprise SD-WLANs," *Journal of Network and Systems Management*, vol. 28, no. 4, pp. 850–881, Oct. 2020.
- [62] E. Coronado, A. Thomas, S. Bayhan, and R. Riggio, "aiOS: An Intelligence Layer for SD-WLANs," in *IEEE/IFIP Network Operations and Management Symposium (NOMS 2020)*, Budapest, Hungary: IEEE, Apr. 2020, pp. 1–9.
- [63] S. Khastoo, T. Brecht, and A. Abedi, "NeuRA: Using Neural Networks to Improve WiFi Rate Adaptation," in *Proceedings of the 23rd International ACM Conference on Modeling, Analysis and Simulation of Wireless and Mobile Systems*, ser. MSWiM '20, Alicante, Spain: Association for Computing Machinery, 2020, pp. 161–170.
- [64] H. Hassani, F. Gringoli, and D. J. Leith, "Quick & plenty: Achieving low delay & high rate in 802.11ac edge networks," *Computer Networks*, vol. 187, p. 107 820, Mar. 2021.
- [65] A. Kashyap, U. Paul, and S. R. Das, "Deconstructing Interference Relations in WiFi Networks," in *2010 7th Annual IEEE Communications Society Conference on Sensor, Mesh and Ad Hoc Communications and Networks (SECON)*, ISSN: 2155-5494, Jun. 2010, pp. 1–9.
- [66] S. Lee and C.-K. Kim, "D-Fi: A diversity-aware Wi-Fi using an OFDM-based Bloom filter," in *2012 20th IEEE International Conference on Network Protocols (ICNP)*, 2012, pp. 1–10.
- [67] S. Lee, J. Choi, J. Yoo, and C.-K. Kim, "Frequency Diversity-Aware Wi-Fi Using OFDM-Based Bloom Filters," *IEEE Transactions on Mobile Computing*, vol. 14, no. 3, pp. 525–537, 2015.
- [68] J. Herzen, H. Lundgren, and N. Hegde, "Learning Wi-Fi performance," in *2015 12th Annual IEEE International Conference on Sensing, Communication, and Networking (SECON)*, 2015, pp. 118–126.
- [69] E. Almazrouei, G. Gianini, N. Almoosa, and E. Damiani, "A Deep Learning Approach to Radio Signal Denoising," in *2019 IEEE Wireless Communications and Networking Conference Workshop (WCNCW)*, 2019, pp. 1–8.
- [70] C. Saha and H. S. Dhillon, "Interference Characterization in Wireless Networks: A Determinantal Learning Approach," in *2019 IEEE 29th*

- International Workshop on Machine Learning for Signal Processing (MLSP)*, 2019, pp. 1–6.
- [71] E. Almazrouei, G. Gianini, C. Mio, N. Almoosa, and E. Damiani, “Using AutoEncoders for Radio Signal Denoising,” in *Proceedings of the 15th ACM International Symposium on QoS and Security for Wireless and Mobile Networks*, 2019, pp. 11–17.
- [72] J. D. Herath, A. Seetharam, and A. Ramesh, “A Deep Learning Model for Wireless Channel Quality Prediction,” in *ICC 2019 - 2019 IEEE International Conference on Communications (ICC)*, 2019, pp. 1–6.
- [73] G. Zhao, Y. Li, C. Xu, Z. Han, Y. Xing, and S. Yu, “Joint Power Control and Channel Allocation for Interference Mitigation Based on Reinforcement Learning,” *IEEE Access*, vol. 7, pp. 177 254–177 265, 2019.
- [74] G. Peserico, T. Fedullo, A. Morato, S. Vitturi, and F. Tramarin, “Rate Adaptation by Reinforcement Learning for Wi-Fi Industrial Networks,” in *2020 25th IEEE International Conference on Emerging Technologies and Factory Automation (ETFA)*, ISSN: 1946-0759, vol. 1, Sep. 2020, pp. 1139–1142.
- [75] H. Feng, Y. Shu, S. Wang, and M. Ma, “SVM-based models for predicting WLAN traffic,” in *2006 IEEE International Conference on Communications*, IEEE, vol. 2, 2006, pp. 597–602.
- [76] M. Barabas, G. Boanea, A. B. Rus, V. Dobrota, and J. Domingo-Pascual, “Evaluation of network traffic prediction based on neural networks with multi-task learning and multiresolution decomposition,” in *2011 IEEE 7th International Conference on Intelligent Computer Communication and Processing*, 2011, pp. 95–102.
- [77] M. A. Khan, R. Hamila, N. A. Al-Emadi, S. Kiranyaz, and M. Gabbouj, “Real-time throughput prediction for cognitive Wi-Fi networks,” *Journal of Network and Computer Applications*, vol. 150, p. 102 499, Jan. 2020.
- [78] A. Azzouni and G. Pujolle, “NeuTM: A neural network-based framework for traffic matrix prediction in SDN,” in *NOMS 2018 - 2018 IEEE/IFIP Network Operations and Management Symposium*, 2018, pp. 1–5.
- [79] S. Yun, Y. Yi, J. Shin, and D. Y. Eun, “Optimal CSMA: A survey,” in *2012 IEEE International Conference on Communication Systems (ICCS)*, Nov. 2012, pp. 199–204.
- [80] S. Moon, S. Ahn, K. Son, J. Park, and Y. Yi, “Neuro-DCF: Design of Wireless MAC via Multi-Agent Reinforcement Learning Approach,” 2021.
- [81] R. Ali, N. Shahin, Y. Kim, B.-S. Kim, and S. Kim, “Channel observation-based scaled backoff mechanism for high-efficiency WLANs,” *Electronics Letters*, vol. 54, Apr. 2018.
- [82] P. Gawlowicz and A. Zubow, “ns-3 meets OpenAI Gym: The Playground for Machine Learning in Networking Research,” in *22nd ACM International Conference on Modelling, Analysis and Simulation of Wireless and Mobile Systems (MSWiM 2019)*, Miami Beach, FL: ACM, Nov. 2019.
- [83] M. Hessel, J. Modayil, H. Van Hasselt, T. Schaul, G. Ostrovski, W. Dabney, D. Horgan, B. Piot, M. Azar, and D. Silver, “Rainbow: Combining improvements in deep reinforcement learning,” in *Thirty-second AAAI conference on artificial intelligence*, 2018.
- [84] Jie Hui and M. Devetsikiotis, “A unified model for the performance analysis of IEEE 802.11e EDCA,” *IEEE Transactions on Communications*, vol. 53, no. 9, pp. 1498–1510, Sep. 2005, Conference Name: IEEE Transactions on Communications.
- [85] K. Kosek-Szott and N. Rapacz, “Tuning Wi-Fi traffic differentiation by combining frame aggregation with TXOP limits,” *IEEE Communications Letters*, vol. 24, no. 3, pp. 700–703, 2019.
- [86] E. Perahia and M. X. Gong, “Gigabit Wireless LANs: An Overview of IEEE 802.11ac and 802.11ad,” *SIGMOBILE Mob. Comput. Commun. Rev.*, vol. 15, no. 3, pp. 23–33, Nov. 2011.
- [87] R. Karmakar, S. Chattopadhyay, and S. Chakraborty, “Impact of IEEE 802.11n/ac PHY/MAC High Throughput Enhancements on Transport and Application Protocols—A Survey,” *IEEE Communications Surveys & Tutorials*, vol. 19, no. 4, pp. 2050–2091, 2017.
- [88] F. Fietkau, *Minstrel HT Linux Wireless*, 2020. [Online]. Available: <https://wireless.wiki.kernel.org/en/developers/documentation/mac80211/ratecontrol/minstrel> (visited on 06/18/2021).
- [89] R. Karmakar, S. Chattopadhyay, and S. Chakraborty, “An online learning approach for auto link-configuration in IEEE 802.11ac wireless networks,” *Computer Networks*, vol. 181, p. 107 426, 2020.
- [90] —, “IEEE 802.11ac Link Adaptation Under Mobility,” in *2017 IEEE 42nd Conference on Local Computer Networks (LCN)*, 2017, pp. 392–400.
- [91] —, “SmartLA: Reinforcement learning-based link adaptation for high throughput wireless access networks,” *Computer Communications*, vol. 110, pp. 1–25, 2017.
- [92] D. Skordoulis, Q. Ni, H.-h. Chen, A. P. Stephens, C. Liu, and A. Jamalipour, “IEEE 802.11n MAC frame aggregation mechanisms for next-generation high-throughput WLANs,” *IEEE Wireless Communications*, vol. 15, no. 1, pp. 40–47, 2008.
- [93] A. Abedi, T. Brecht, and O. Abari, “PNOFA: Practical, Near-Optimal Frame Aggregation for Modern 802.11 Networks,” in *Proceedings of the 23rd International ACM Conference on Modeling, Analysis and Simulation of Wireless and Mobile Systems*, ser. MSWiM ’20, Alicante, Spain: Association for Computing Machinery, 2020, pp. 63–72.
- [94] A. Thapaliya, J. Schnebly, and S. Sengupta, “Predicting Congestion Level in Wireless Networks Using an Integrated Approach of Supervised and Unsupervised Learning,” in *2018 9th IEEE Annual Ubiquitous Computing, Electronics Mobile Communication Conference (UEMCON)*, 2018, pp. 977–982.
- [95] Y. Kim, S. An, and J. So, “Identifying signal source using channel state information in wireless LANs,” in *2018 International Conference on Information Networking (ICOIN)*, 2018, pp. 616–621.
- [96] X. Lin, N. Shroff, and R. Srikant, “A tutorial on cross-layer optimization in wireless networks,” *IEEE Journal on Selected Areas in Communications*, vol. 24, no. 8, pp. 1452–1463, 2006.
- [97] E. M. Mohamed, K. Sakaguchi, and S. Sampei, “Wi-Fi coordinated WiGig concurrent transmissions in random access scenarios,” *IEEE Transactions on Vehicular Technology*, vol. 66, no. 11, pp. 10 357–10 371, 2017.
- [98] E. Kurniawan, L. Zhiwei, and S. Sun, “Machine learning-based channel classification and its application to IEEE 802.11ad communications,” in *GLOBECOM 2017-2017 IEEE Global Communications Conference*, IEEE, 2017, pp. 1–6.
- [99] L. Bai, C.-X. Wang, J. Huang, Q. Xu, Y. Yang, G. Goussetis, J. Sun, and W. Zhang, “Predicting Wireless MmWave Massive MIMO Channel Characteristics Using Machine Learning Algorithms,” *Wireless Communications and Mobile Computing*, vol. 2018, p. 9 783 863, Aug. 2018.
- [100] P. Zhou, X. Fang, X. Wang, Y. Long, R. He, and X. Han, “Deep Learning-Based Beam Management and Interference Coordination in Dense mmWave Networks,” *IEEE Transactions on Vehicular Technology*, vol. 68, no. 1, pp. 592–603, 2019.
- [101] T. Chang, L. Shen, and K. Feng, “Learning-Based Beam Training Algorithms for IEEE802.11ad/ay Networks,” in *2019 IEEE 89th Vehicular Technology Conference (VTC2019-Spring)*, 2019, pp. 1–5.
- [102] T. Nishio, H. Okamoto, K. Nakashima, Y. Koda, K. Yamamoto, M. Morikura, Y. Asai, and R. Miyatake, “Proactive Received Power Prediction Using Machine Learning and Depth Images for mmWave Networks,” *IEEE Journal on Selected Areas in Communications*, vol. 37, no. 11, pp. 2413–2427, 2019.
- [103] T. Azzino, T. Ropitault, and M. Zorzi, “Scheduling the Data Transmission Interval in IEEE 802.11ad: A Reinforcement Learning Approach,” in *2020 International Conference on Computing, Networking and Communications (ICNC)*, 2020, pp. 602–607.
- [104] S. Mohebi, M. Lecci, A. Zanella, and M. Zorzi, “The Challenges of Scheduling and Resource Allocation in IEEE 802.11ad/ay,” in *2020 Mediterranean Communication and Computer Networking Conference (MedComNet)*, 2020, pp. 1–4.
- [105] B. Salehi, M. Belgiovine, S. G. Sanchez, J. Dy, S. Ioannidis, and K. Chowdhury, “Machine Learning on Camera Images for Fast mmWave Beamforming,” in *2020 IEEE 17th International Conference on Mobile Ad Hoc and Sensor Systems (MASS)*, 2020, pp. 338–346.
- [106] X. Lin, L. Zhang, and Y. Jiang, “Location Aided Intelligent Deep Learning Channel Estimation for Millimeter Wave Communications,” in *2020 IEEE/CIC International Conference on Communications in China (ICCC)*, 2020, pp. 489–494.
- [107] S. Aggarwal, U. S. Sardesai, V. Sinha, D. D. Mohan, M. Ghoshal, and D. Koutsonikolas, “LiBRA: Learning-Based Link Adaptation Leveraging PHY Layer Information in 60 GHz WLANs,” in *Proceedings of the 16th International Conference on Emerging Networking EXperiments and Technologies*, ser. CoNEXT ’20, Barcelona, Spain: Association for Computing Machinery, 2020, pp. 245–260.
- [108] S. Aggarwal, U. S. Sardesai, V. Sinha, and D. Koutsonikolas, “An Experimental Study of Rate and Beam Adaptation in 60 GHz WLANs,” in *Proceedings of the 23rd International ACM Conference on Modeling, Analysis and Simulation of Wireless and Mobile Systems*, ser. MSWiM ’20, Alicante, Spain: Association for Computing Machinery, 2020, pp. 171–180.

- [109] Y. Koda, K. Nakashima, K. Yamamoto, T. Nishio, and M. Morikura, "Handover Management for mmWave Networks With Proactive Performance Prediction Using Camera Images and Deep Reinforcement Learning," *IEEE Transactions on Cognitive Communications and Networking*, vol. 6, no. 2, pp. 802–816, 2020.
- [110] T. H. Ly Dinh, M. Kaneko, K. Wakao, K. Kawamura, T. Moriyama, H. Abeysekera, and Y. Takatori, "Deep Reinforcement Learning-based User Association in Sub6GHz/mmWave Integrated Networks," in *2021 IEEE 18th Annual Consumer Communications Networking Conference (CCNC)*, 2021.
- [111] L.-H. Shen, T.-W. Chang, K.-T. Feng, and P.-T. Huang, "Design and Implementation for Deep Learning Based Adjustable Beamforming Training for Millimeter Wave Communication Systems," *IEEE Transactions on Vehicular Technology*, vol. 70, no. 3, pp. 2413–2427, 2021.
- [112] M. Polese, F. Restuccia, and T. Melodia, "DeepBeam: Deep Waveform Learning for Coordination-Free Beam Management in MmWave Networks," in *Proceedings of the Twenty-Second International Symposium on Theory, Algorithmic Foundations, and Protocol Design for Mobile Networks and Mobile Computing*, ser. MobiHoc '21, Shanghai, China: Association for Computing Machinery, 2021, pp. 61–70.
- [113] A. Rico-Alvarino and R. W. Heath, "Learning-based adaptive transmission for limited feedback multiuser MIMO-OFDM," *IEEE Transactions on Wireless Communications*, vol. 13, no. 7, pp. 3806–3820, 2014.
- [114] R. Karmakar, S. Chattopadhyay, and S. Chakraborty, "Intelligent MU-MIMO user selection with dynamic link adaptation in IEEE 802.11ax," *IEEE Transactions on Wireless Communications*, vol. 18, no. 2, pp. 1155–1165, 2019.
- [115] S. Su, W.-T. Tan, X. Zhu, and R. Liston, "Client Pre-Screening for MU-MIMO in Commodity 802.11ac Networks via Online Learning," in *IEEE INFOCOM 2019-IEEE Conference on Computer Communications*, IEEE, 2019, pp. 649–657.
- [116] R. Balakrishnan, K. Sankhe, V. S. Somayazulu, R. Vannithamby, and J. Sydir, "Deep reinforcement learning based traffic-and channel-aware OFDMA resource allocation," in *2019 IEEE Global Communications Conference (GLOBECOM)*, IEEE, 2019, pp. 1–6.
- [117] P. K. Sangdeh, H. Pirayesh, A. Mobiny, and H. Zeng, "LB-SciFi: Online Learning-Based Channel Feedback for MU-MIMO in Wireless LANs," in *2020 IEEE 28th International Conference on Network Protocols (ICNP)*, IEEE, 2020, pp. 1–11.
- [118] D. Kotagiri, K. Nihei, and T. Li, "Multi-User Distributed Spectrum Access Method for 802.11ax Stations," in *2020 29th International Conference on Computer Communications and Networks (ICCCN)*, IEEE, 2020.
- [119] —, "Distributed Convolutional Deep Reinforcement Learning based OFDMA MAC for 802.11ax," in *ICC 2021-IEEE International Conference on Communications*, IEEE, 2021.
- [120] S. Su, W.-T. Tan, X. Zhu, R. Liston, and B. Aazhang, "Data-Driven Mode and Group Selection for Downlink MU-MIMO With Implementation in Commodity 802.11ac Network," *IEEE Transactions on Communications*, vol. 69, no. 3, pp. 1620–1634, 2021.
- [121] P. K. Sangdeh and H. Zeng, "DeepMux: Deep-Learning-Based Channel Sounding and Resource Allocation for IEEE 802.11ax," *IEEE Journal on Selected Areas in Communications*, vol. 39, no. 8, pp. 2333–2346, 2021.
- [122] Z. Hu and C.-K. Tham, "CCMAC: Coordinated cooperative MAC for wireless LANs," in *Proceedings of the 11th international symposium on Modeling, analysis and simulation of wireless and mobile systems*, 2008, pp. 60–69.
- [123] M. Timmers, S. Pollin, A. Dejonghe, L. Van der Perre, and F. Catthoor, "A spatial learning algorithm for IEEE 802.11 networks," in *2009 IEEE International Conference on Communications*, IEEE, 2009, pp. 1–6.
- [124] D. H. Nguyen, A. Paatelma, H. Saarnisaari, N. Kandasamy, and K. R. Dandekar, "Enhancing indoor spatial reuse through adaptive antenna beamsteering," in *Proceedings of the Tenth ACM International Workshop on Wireless Network Testbeds, Experimental Evaluation, and Characterization*, 2016, pp. 81–82.
- [125] F. Wilhelmi, B. Bellalta, C. Cano, and A. Jonsson, "Implications of decentralized Q-learning resource allocation in wireless networks," in *2017 IEEE 28th Annual International Symposium on Personal, Indoor, and Mobile Radio Communications (PIMRC)*, 2017, pp. 1–5.
- [126] F. Wilhelmi, S. Barrachina-Muñoz, B. Bellalta, C. Cano, A. Jonsson, and G. Neu, "Potential and pitfalls of multi-armed bandits for decentralized spatial reuse in WLANs," *Journal of Network and Computer Applications*, vol. 127, pp. 26–42, 2019.
- [127] F. Wilhelmi, C. Cano, G. Neu, B. Bellalta, A. Jonsson, and S. Barrachina-Muñoz, "Collaborative spatial reuse in wireless networks via selfish multi-armed bandits," *Ad Hoc Networks*, vol. 88, pp. 129–141, 2019.
- [128] Á. López-Raventós, F. Wilhelmi, S. Barrachina-Muñoz, and B. Bellalta, "Combining software defined networks and machine learning to enable self organizing WLANs," in *2019 International Conference on Wireless and Mobile Computing, Networking and Communications (WiMob)*, IEEE, 2019, pp. 1–8.
- [129] E. Ak and B. Canberk, "FSC: Two-Scale AI-Driven Fair Sensitivity Control for 802.11ax Networks," in *GLOBECOM 2020-2020 IEEE Global Communications Conference*, IEEE, 2020, pp. 1–6.
- [130] B. Yin, K. Yamamoto, T. Nishio, M. Morikura, and H. Abeysekera, "Learning-Based Spatial Reuse for WLANs With Early Identification of Interfering Transmitters," *IEEE Transactions on Cognitive Communications and Networking*, vol. 6, no. 1, pp. 151–164, 2019.
- [131] K. Ayush, R. Karmakar, V. Rawal, P. K. Bishoyi, S. Chattopadhyay, and S. Chakraborty, "Supporting Throughput Fairness in IEEE 802.11ac Dynamic Bandwidth Channel Access: A Hybrid Approach," in *2017 IEEE 42nd Conference on Local Computer Networks (LCN)*, IEEE, 2017, pp. 462–470.
- [132] A. Barrachina-Munoz Chiumento and B. Bellalta, "Stateless Reinforcement Learning for Multi-Agent Systems: the Case of Spectrum Allocation in Dynamic Channel Bonding WLANs," in *2021 Wireless Days (WD)*, IEEE, 2021, pp. 1–8.
- [133] R. Karmakar, S. Chattopadhyay, and S. Chakraborty, "Learning Based Adaptive Fair QoS in IEEE 802.11ac Access Networks," in *2019 11th International Conference on Communication Systems & Networks (COMSNETS)*, IEEE, 2019, pp. 22–29.
- [134] Z. Khan and J. J. Lehtomäki, "Interactive Trial and Error Learning Method for Distributed Channel Bonding: Model, Prototype Implementation, and Evaluation," *IEEE Transactions on Cognitive Communications and Networking*, vol. 5, no. 2, pp. 206–223, 2019.
- [135] H. Qi, H. Huang, Z. Hu, X. Wen, and Z. Lu, "On-Demand Channel Bonding in Heterogeneous WLANs: A Multi-Agent Deep Reinforcement Learning Approach," *Sensors*, vol. 20, no. 10, p. 2789, 2020.
- [136] Y. Luo and K.-W. Chin, "Learning to Bond in Dense WLANs With Random Traffic Demands," *IEEE Transactions on Vehicular Technology*, vol. 69, no. 10, pp. 11 868–11 879, 2020.
- [137] R. Karmakar, S. Chattopadhyay, and S. Chakraborty, "SmartBond: A deep probabilistic machinery for smart channel bonding in IEEE 802.11ac," in *IEEE INFOCOM 2020-IEEE Conference on Computer Communications*, IEEE, 2020, pp. 2599–2608.
- [138] H. Kanemasa, A. Li, M. Naruse, N. Chauvet, and M. Hasegawa, "Dynamic Channel Bonding Using Laser Chaos Decision Maker in WLANs," in *2021 International Conference on Artificial Intelligence in Information and Communication (ICAIIIC)*, IEEE, 2021, pp. 078–082.
- [139] F. Wilhelmi, D. Góez, P. Soto, R. Vallés, M. Alfaihi, A. Algunayah, J. Martín-Pérez, L. Girletti, R. Mohan, K. V. Ramnan, et al., "Machine Learning for Performance Prediction of Channel Bonding in Next-Generation IEEE 802.11 WLANs," *arXiv preprint arXiv:2105.14219*, 2021.
- [140] P. Soto, M. Camelo, K. Mets, F. Wilhelmi, D. Góez, L. A. Fletscher, N. Gaviria, P. Hellinckx, J. F. Botero, and S. Latré, "ATARI: A Graph Convolutional Neural Network Approach for Performance Prediction in Next-Generation WLANs," *Sensors*, vol. 21, no. 13, p. 4321, 2021.
- [141] K. Yano, N. Egashira, J. Webber, M. Usui, and Y. Suzuki, "Achievable throughput of multiband wireless LAN using simultaneous transmission over multiple primary channels assisted by idle length prediction based on PNN," in *2019 International Conference on Artificial Intelligence in Information and Communication (ICAIIIC)*, IEEE, 2019, pp. 022–027.
- [142] N. N. Krishnan, E. Torkildson, N. B. Mandayam, D. Raychaudhuri, E.-H. Rantala, and K. Doppler, "Optimizing throughput performance in distributed MIMO Wi-Fi networks using deep reinforcement learning," *IEEE Transactions on Cognitive Communications and Networking*, vol. 6, no. 1, pp. 135–150, 2019.
- [143] Y. Zhang, Q. Wu, and M. Shikh-Bahaee, "A Pointer Network Based Deep Learning Algorithm for User Pairing in Full-Duplex Wi-Fi Networks," *IEEE Transactions on Vehicular Technology*, vol. 69, no. 10, pp. 12 363–12 368, 2020.
- [144] E. H. Ong, J. Knecht, O. Alanen, Z. Chang, T. Huovinen, and T. Nihtilä, "IEEE 802.11ac: Enhancements for very high throughput WLANs," in *2011 IEEE 22nd International Symposium on Personal, Indoor and Mobile Radio Communications*, IEEE, 2011, pp. 849–853.
- [145] D. López-Pérez, A. Garcia-Rodríguez, L. Galati-Giordano, M. Kasslin, and K. Doppler, "IEEE 802.11be extremely high throughput: The next generation of Wi-Fi technology beyond 802.11ax," *IEEE Communications Magazine*, vol. 57, no. 9, pp. 113–119, 2019.

- [146] B. Bellalta and K. Kosek-Szott, "AP-initiated multi-user transmissions in IEEE 802.11ax WLANs," *Ad Hoc Networks*, vol. 85, pp. 145–159, 2019.
- [147] G. Naik, J.-M. Park, J. Ashdown, and W. Lehr, "Next generation Wi-Fi and 5G NR-U in the 6 GHz bands: Opportunities and challenges," *IEEE Access*, vol. 8, pp. 153 027–153 056, 2020.
- [148] K. Aldubaikhy, W. Wu, N. Zhang, N. Cheng, and X. Shen, "mmWave IEEE 802.11ay for 5G Fixed Wireless Access," *IEEE Wireless Communications*, vol. 27, no. 2, pp. 88–95, 2020.
- [149] I.-S. Comsa, S. Zhang, M. Aydin, P. Kuonen, R. Trestian, and G. Ghinea, "A comparison of reinforcement learning algorithms in fairness-oriented OFDMA schedulers," *Information*, vol. 10, no. 10, p. 315, 2019.
- [150] I.-S. Comsa, S. Zhang, M. Aydin, P. Kuonen, R. Trestian, and G. Ghinea, "Enhancing user fairness in OFDMA radio access networks through machine learning," in *2019 Wireless Days (WD)*, IEEE, 2019, pp. 1–8.
- [151] A. Li, Y. Me, S. Xue, N. Yi, and R. Tafazolli, "A carrier-frequency-offset resilient OFDMA receiver designed through machine deep learning," in *2018 IEEE 29th Annual International Symposium on Personal, Indoor and Mobile Radio Communications (PIMRC)*, IEEE, 2018, pp. 1–6.
- [152] A. Li, Y. Ma, S. Xue, N. Yi, R. Tafazolli, and T. E. Dogson, "Unsupervised deep learning for blind multiuser frequency synchronization in OFDMA uplink," in *ICC 2019-2019 IEEE International Conference on Communications (ICC)*, IEEE, 2019, pp. 1–6.
- [153] A. Galindo-Serrano and L. Giupponi, "Distributed Q-learning for interference control in OFDMA-based femtocell networks," in *2010 IEEE 71st Vehicular Technology Conference*, IEEE, 2010, pp. 1–5.
- [154] X. Yang, Y. Wang, D. Zhang, and L. Cuthbert, "Resource allocation in LTE OFDMA systems using genetic algorithm and semi-smart antennas," in *2010 IEEE Wireless Communication and Networking Conference*, IEEE, 2010, pp. 1–6.
- [155] I. Jamil, L. Cariou, and J.-F. Hélar, "Novel learning-based spatial reuse optimization in dense WLAN deployments," *EURASIP Journal on Wireless Communications and Networking*, vol. 2016, no. 1, pp. 1–19, 2016.
- [156] P. Auer, N. Cesa-Bianchi, Y. Freund, and R. E. Schapire, "Gambling in a rigged casino: The adversarial multi-armed bandit problem," in *Proceedings of IEEE 36th Annual Foundations of Computer Science*, IEEE, 1995, pp. 322–331.
- [157] P. Auer, N. Cesa-Bianchi, and P. Fischer, "Finite-time analysis of the multiarmed bandit problem," *Machine learning*, vol. 47, no. 2, pp. 235–256, 2002.
- [158] W. R. Thompson, "On the likelihood that one unknown probability exceeds another in view of the evidence of two samples," *Biometrika*, vol. 25, no. 3/4, pp. 285–294, 1933.
- [159] S. Barrachina-Munoz, F. Wilhelm, I. Selinis, and B. Bellalta, "Komondor: A wireless network simulator for next-generation high-density WLANs," in *2019 Wireless Days (WD)*, IEEE, 2019, pp. 1–8.
- [160] O. Jeunen, P. Bosch, M. Van Herwegen, K. Van Doorselaer, N. Godman, and S. Latré, "A machine learning approach for IEEE 802.11 channel allocation," in *2018 14th International Conference on Network and Service Management (CNSM)*, IEEE, 2018, pp. 28–36.
- [161] K. Nakashima, S. Kamiya, K. Ohtsu, K. Yamamoto, T. Nishio, and M. Morikura, "Deep Reinforcement Learning-Based Channel Allocation for Wireless LANs With Graph Convolutional Networks," *IEEE Access*, vol. 8, pp. 31 823–31 834, Jan. 2020.
- [162] Y. Liu, B. R. Tamma, B. S. Manoj, and R. Rao, "On Cognitive Network Channel Selection and the Impact on Transport Layer Performance," in *IEEE Global Communications Conference (GLOBECOM 2010)*, Miami, FL: IEEE, Dec. 2010, pp. 1–5.
- [163] B. Bojovic, N. Baldo, J. Nin-Guerrero, and P. Dini, "A supervised learning approach to cognitive access point selection," in *IEEE Global Communications Conference (GLOBECOM 2011)*, Houston, TX: IEEE, Dec. 2011, pp. 1100–1105.
- [164] T. H. L. Dinh, M. Kaneko, K. Wakao, K. Kawamura, T. Moriyama, H. Abeysekera, and Y. Takatori, "Distributed user-to-multiple access points association through deep learning for beyond 5G," *Elsevier Computer Networks (COMNET)*, vol. 197, p. 108 258, 2021.
- [165] C. Pei, Z. Wang, Y. Zhao, Z. Wang, Y. Meng, D. Pei, Y. Peng, W. Tang, and X. Qu, "Why it takes so long to connect to a WiFi access point," in *IEEE INFOCOM 2017 - IEEE Conference on Computer Communications*, IEEE, May 2017, pp. 1–9.
- [166] L. Song and A. Striegel, "Leveraging frame aggregation to improve access point selection," in *36th IEEE Conference on Computer Communications (INFOCOM 2017)*, Atlanta, GA: IEEE, May 2017, pp. 325–330.
- [167] M. Feltrin and S. Tomasin, "A Machine-Learning-Based Handover Prediction for Anticipatory Techniques in Wi-Fi Networks," in *2018 Tenth International Conference on Ubiquitous and Future Networks (ICUFN)*, Prague, Czechia: IEEE, Jul. 2018, pp. 341–345.
- [168] M. Carrascosa and B. Bellalta, "Decentralized AP selection using Multi-Armed Bandits: Opportunistic ϵ -Greedy with Stickiness," in *IEEE Symposium on Computers and Communications (ISCC 2019)*, Barcelona, Spain: IEEE, Jun. 2019, pp. 1–7.
- [169] M. A. Kafi, A. Mouradian, and V. Vèque, "On-line Client Association Scheme Based on Reinforcement Learning for WLAN Networks," in *IEEE Wireless Communications and Networking Conference (WCNC 2019)*, Marrakesh, Morocco: IEEE, Apr. 2019, pp. 1–7.
- [170] Z. Han, T. Lei, Z. Lu, X. Wen, W. Zheng, and L. Guo, "Artificial Intelligence-Based Handoff Management for Dense WLANs: A Deep Reinforcement Learning Approach," *IEEE Access*, vol. 7, pp. 31 688–31 701, Jan. 2019.
- [171] E. Zeljković, N. Slamnik-Kriještorac, S. Latré, and J. M. Marquez-Barja, "ABRAHAM: Machine Learning Backed Proactive Handover Algorithm Using SDN," *IEEE Transactions on Network and Service Management*, vol. 16, no. 2, pp. 1522–1536, Sep. 2019.
- [172] Á. López-Raventós and B. Bellalta, "Concurrent decentralized channel allocation and access point selection using multi-armed bandits in multi BSS WLANs," *Computer Networks*, vol. 180, p. 107 381, 2020.
- [173] M. Carrascosa and B. Bellalta, "Multi-armed bandits for decentralized AP selection in enterprise WLANs," *Computer Communications*, vol. 159, pp. 108–123, 2020.
- [174] S. d. Bast, R. Torrea-Duran, A. Chiumento, S. Pollin, and H. Gacanin, "Deep Reinforcement Learning for Dynamic Network Slicing in IEEE 802.11 Networks," in *38th IEEE Conference on Computer Communications (INFOCOM 2019)*, Paris, France: IEEE, Apr. 2019, pp. 264–269.
- [175] F. Lyu, L. Fang, G. Xue, H. Xue, and M. Li, "Large-Scale Full WiFi Coverage: Deployment and Management Strategy Based on User Spatio-Temporal Association Analytics," *IEEE Internet of Things Journal*, vol. 6, no. 6, pp. 9386–9398, Dec. 2019.
- [176] P. Gallo and D. Garlisi, "Wi-Dia: Data-Driven Wireless Diagnostic Using Context Recognition," in *2018 IEEE 4th International Forum on Research and Technology for Society and Industry (RTSI)*, Palermo, Italy: IEEE, Sep. 2018, pp. 1–6.
- [177] I. Syrigos, N. Sakellariou, S. Keranidis, and T. Korakis, "On the Employment of Machine Learning Techniques for Troubleshooting WiFi Networks," in *IEEE Consumer Communications and Networking Conference (CCNC 2019)*, Las Vegas, NV: IEEE, Jan. 2019, pp. 1–6.
- [178] N. Trivedi, B. Panigrahi, and H. K. Rath, "WiNetSense: Sensing and Analysis Model for Large-scale Wireless Networks," in *39th IEEE International Conference on Computer Communications (INFOCOM 2020)*, Virtual Conference: IEEE, Jul. 2020, pp. 787–792.
- [179] A. Allahdadi, D. Pernes, J. S. Cardoso, and R. Morla, "Hidden Markov Models on a Self-Organizing Map for Anomaly Detection in 802.11 Wireless Networks," *Neural Computing and Applications*, vol. 33, pp. 8777–8794, 2021.
- [180] M. Karaca and B. Landfeldt, "Load-aware channel selection for 802.11 WLANs with limited measurement," in *23rd International Conference on Telecommunications (ICT 2016)*, Thessaloniki, Greece: IEEE, May 2016, pp. 1–5.
- [181] A. Patro and S. Banerjee, "Outsourcing coordination and management of home wireless access points through an open API," in *2015 IEEE Conference on Computer Communications (INFOCOM)*, IEEE, 2015, pp. 1454–1462.
- [182] M. Morshedi and J. Noll, "Estimating PQoS of Video Streaming on Wi-Fi Networks Using Machine Learning," *MDPI Sensors*, vol. 21, no. 2, 2021.
- [183] N. Rupasinghe and İ. Güvenc, "Reinforcement learning for licensed-assisted access of LTE in the unlicensed spectrum," in *2015 IEEE Wireless Communications and Networking Conference (WCNC)*, IEEE, 2015, pp. 1279–1284.
- [184] J. Xu, Y. Gao, Y. Liu, X. Zhang, and P. Li, "Dynamic max TxOP algorithms in licensed-assisted access system," in *2016 8th International Conference on Wireless Communications & Signal Processing (WCSP)*, IEEE, 2016, pp. 1–5.
- [185] S. Lin and J. Yu, "Fairly Coexistence of LTE and WiFi: A Markov Game Framework," in *2017 IEEE Globecom Workshops (GC Wkshps)*, IEEE, 2017, pp. 1–6.
- [186] Y.-Y. Liu and S.-J. Yoo, "Dynamic resource allocation using reinforcement learning for LTE-U and WiFi in the unlicensed spectrum,"

- in *2017 Ninth International Conference on Ubiquitous and Future Networks (ICUFN)*, IEEE, 2017, pp. 471–475.
- [187] A. K. Bairagi, S. F. Abedin, N. H. Tran, D. Niyato, and C. S. Hong, “QoE-enabled unlicensed spectrum sharing in 5G: A game-theoretic approach,” *IEEE Access*, vol. 6, pp. 50 538–50 554, 2018.
- [188] J. Tan, S. Xiao, S. Han, and Y.-C. Liang, “A learning-based coexistence mechanism for LAA-LTE based HetNets,” in *2018 IEEE International Conference on Communications (ICC)*, IEEE, 2018, pp. 1–6.
- [189] M. Haider and M. Erol-Kantarci, “Enhanced LBT mechanism for LTE-unlicensed using reinforcement learning,” in *2018 IEEE Canadian Conference on Electrical & Computer Engineering (CCECE)*, IEEE, 2018, pp. 1–4.
- [190] V. Maglogiannis, D. Naudts, A. Shahid, and I. Moerman, “A Q-learning scheme for fair coexistence between LTE and Wi-Fi in unlicensed spectrum,” *IEEE Access*, vol. 6, pp. 27 278–27 293, 2018.
- [191] U. Challita, L. Dong, and W. Saad, “Proactive resource management for LTE in unlicensed spectrum: A deep learning perspective,” *IEEE Transactions on Wireless Communications*, vol. 17, no. 7, pp. 4674–4689, 2018.
- [192] Y. Su, X. Du, L. Huang, Z. Gao, and M. Guizani, “LTE-U and Wi-Fi coexistence algorithm based on Q-learning in multi-channel,” *IEEE Access*, vol. 6, pp. 13 644–13 652, 2018.
- [193] P. Tian, “Traffic-Aware Resource Allocation and Spectrum Share for LTE-U and Wi-Fi,” in *International Conference on Mechatronics and Intelligent Robotics*, Springer, 2019, pp. 837–843.
- [194] K. Zhou, A. Li, C. Dong, L. Zhang, and J. Sun, “LWCQ: An Adaptive Algorithm for LAA and WiFi Coexistence Based on Q-learning,” in *2019 IEEE 19th International Conference on Communication Technology (ICCT)*, IEEE, 2019, pp. 556–560.
- [195] H. Kushwaha, V. J. Kotagi, and C. S. R. Murthy, “A Novel Reinforcement Learning Based Adaptive Optimization of LTE-TDD Configurations for LTE-U/WiFi Coexistence,” in *2019 IEEE 30th Annual International Symposium on Personal, Indoor and Mobile Radio Communications (PIMRC)*, IEEE, 2019, pp. 1–7.
- [196] S. Mosleh, Y. Ma, J. D. Rezac, and J. B. Coder, “Dynamic spectrum access with reinforcement learning for unlicensed access in 5G and beyond,” in *2020 IEEE 91st Vehicular Technology Conference (VTC2020-Spring)*, IEEE, 2020, pp. 1–7.
- [197] M. Han, S. Khairy, L. X. Cai, Y. Cheng, and R. Zhang, “Reinforcement Learning for Efficient and Fair Coexistence Between LTE-LAA and Wi-Fi,” *IEEE Transactions on Vehicular Technology*, vol. 69, no. 8, pp. 8764–8776, 2020.
- [198] J. Tan, L. Zhang, Y.-C. Liang, and D. Niyato, “Intelligent sharing for LTE and WiFi systems in unlicensed bands: A deep reinforcement learning approach,” *IEEE Transactions on Communications*, vol. 68, no. 5, pp. 2793–2808, 2020.
- [199] J. M. de C Neto, S. F. G Neto, P. M. de Santana, and V. A. de Sousa, “Multi-cell LTE-U/Wi-Fi coexistence evaluation using a reinforcement learning framework,” *Sensors*, vol. 20, no. 7, p. 1855, 2020.
- [200] R. Ali, B. Kim, S. W. Kim, H. Kim, and F. Ishmanov, “(Re)LBT: A Reinforcement learning-enabled listen before talk mechanism for LTE-LAA and Wi-Fi coexistence in IoT,” *Computer Communications*, vol. 150, pp. 498–505, 2020.
- [201] Q. Tang, M. Zeng, J. Guo, and Z. Fei, “An Almost Blank Subframe Allocation Algorithm for 5G New Radio in Unlicensed Bands,” in *2020 IEEE/CIC International Conference on Communications in China (ICCC)*, IEEE, 2020, pp. 776–781.
- [202] Y. Yu, S. C. Liew, and T. Wang, “Non-uniform time-step deep Q-network for carrier-sense multiple access in heterogeneous wireless networks,” *IEEE Transactions on Mobile Computing*, 2020.
- [203] M. Hirzallah and M. Krunz, “Sense-Bandits: AI-based Adaptation of Sensing Thresholds for Heterogeneous-technology Coexistence Over Unlicensed Bands,” *arXiv preprint arXiv:2105.12834*, 2021.
- [204] Y. Kishimoto, X. Wang, and M. Umehira, “Reinforcement Learning for Joint Channel/Subframe Selection of LTE in the Unlicensed Spectrum,” *Wireless Communications and Mobile Computing*, vol. 2021, 2021.
- [205] K. Naveen and C. Amballa, “Coexistence of LTE-Unlicensed and WiFi: A Reinforcement Learning Framework,” in *2021 International Conference on Communication Systems & NETWORKS (COMSNETS)*, IEEE, 2021, pp. 308–316.
- [206] A. Galanopoulos, F. Foukalas, and T. A. Tsiftsis, “Efficient coexistence of LTE with WiFi in the licensed and unlicensed spectrum aggregation,” *IEEE Transactions on Cognitive Communications and Networking*, vol. 2, no. 2, pp. 129–140, 2016.
- [207] E. Fakhfakh and S. Hamouda, “Incentive reward for efficient WiFi offloading using Q-learning approach,” in *13th International Wireless Communications and Mobile Computing Conference (IWCMC 2017)*, Valencia, Spain: IEEE, Jun. 2017, pp. 1114–1119.
- [208] E. Fakhfakh and S. Hamouda, “Optimised Q-learning for WiFi offloading in dense cellular networks,” *IET Communications*, vol. 11, no. 15, pp. 2380–2385, 2017.
- [209] C. S. Yang, C. K. Kim, J.-M. Moon, S.-H. Park, and C. G. Kang, “Channel access scheme with alignment reference interval adaptation (ARIA) for frequency reuse in unlicensed band LTE: Fuzzy Q-learning approach,” *IEEE Access*, vol. 6, pp. 26 438–26 451, 2018.
- [210] B. Yang, X. Cao, Z. Han, and L. Qian, “A machine learning enabled MAC framework for heterogeneous Internet-of-Things networks,” *IEEE Transactions on Wireless Communications*, vol. 18, no. 7, pp. 3697–3712, 2019.
- [211] T. Pulkkinen, J. K. Nurminen, and P. Nurmi, “Understanding WiFi Cross-technology Interference Detection in the Real World,” in *2020 IEEE 40th International Conference on Distributed Computing Systems (ICDCS)*, IEEE, 2020, pp. 954–964.
- [212] M. Ahmed, B. Gabr, L. H. Afify, A. El-Sherif, K. G. Seddik, and M. Elattar, “Machine Learning-based Module for Monitoring LTE/WiFi Coexistence Networks Dynamics,” in *2021 IEEE International Conference on Communications Workshops (ICC Workshops)*, IEEE, 2021, pp. 1–6.
- [213] E. Fonseca, J. F. Santos, F. Paisana, and L. A. DaSilva, “Radio Access Technology Characterisation Through Object Detection,” *Computer Communications*, vol. 168, pp. 12–19, 2021.
- [214] R. Yin, Z. Zou, C. Wu, J. Yuan, X. Chen, and G. Yu, “Learning-based WiFi traffic load estimation in NR-U systems,” *IEICE Transactions on Fundamentals of Electronics, Communications and Computer Sciences*, vol. 104, no. 2, pp. 542–549, 2021.
- [215] M. Olbrich, A. Zubow, S. Zehl, and A. Wolisz, “WiPLUS: Towards LTE-U Interference Detection, Assessment and Mitigation in 802.11 Networks,” in *European Wireless Conference (EW 2017)*, Dresden, Germany: VDE, May 2017.
- [216] V. Sathya, A. Dziedzic, M. Ghosh, and S. Krishnan, “Machine Learning based Detection of multiple Wi-Fi BSSs for LTE-U CSAT,” in *2020 International Conference on Computing, Networking and Communications (ICNC)*, IEEE, 2020, pp. 596–601.
- [217] H. Gu, Y. Wang, S. Hong, Y. Xu, and G. Gui, “Deep Learning based Intelligent Recognition Method in Heterogeneous Communication Networks,” in *2020 IEEE/CIC International Conference on Communications in China (ICCC)*, IEEE, 2020, pp. 478–482.
- [218] S. Mosleh, Y. Ma, J. D. Rezac, and J. B. Coder, “A Novel Machine Learning Approach to Estimating KPI and PoC for LTE-LAA-Based Spectrum Sharing,” in *2020 IEEE International Conference on Communications Workshops (ICC Workshops)*, 2020, pp. 1–6.
- [219] M. Yang, Y. Song, C. Cai, and H. Gu, “Blind LTE-u/WiFi coexistence system using convolutional neural network,” *IEEE Access*, vol. 8, pp. 15 923–15 930, 2019.
- [220] M. Girmay, A. Shahid, V. Maglogiannis, D. Naudts, and I. Moerman, “Machine Learning Enabled Wi-Fi Saturation Sensing for Fair Coexistence in Unlicensed Spectrum,” *IEEE Access*, vol. 9, pp. 42 959–42 974, 2021.
- [221] R. Ahmad, M. D. Soltani, M. Safari, and A. Srivastava, “Load Balancing of Hybrid LiFi WiFi Networks Using Reinforcement learning,” in *2020 IEEE 31st Annual International Symposium on Personal, Indoor and Mobile Radio Communications*, IEEE, pp. 1–6.
- [222] R. Ahmad, M. D. Soltani, M. Safari, A. Srivastava, and A. Das, “Reinforcement learning based load balancing for hybrid LiFi WiFi networks,” *IEEE Access*, vol. 8, pp. 132 273–132 284, 2020.
- [223] X. Wu and D. C. O’Brien, “A Novel Machine Learning-Based Handover Scheme for Hybrid LiFi and WiFi Networks,” in *2020 IEEE Globecom Workshops (GC Wkshps)*, 2020, pp. 1–5.
- [224] J. Sanusi, S. Idris, S. Adeshina, A. M. Aibinu, and I. Umar, “Development of Handover Decision Algorithms in Hybrid Li-Fi and Wi-Fi Networks,” in *2020 3rd International Conference on Intelligent Sustainable Systems (ICISS)*, IEEE, 2020, pp. 1232–1239.
- [225] W. Ejaz, M. Basharat, S. Saadat, A. M. Khattak, M. Naeem, and A. Anpalagan, “Learning paradigms for communication and computing technologies in IoT systems,” *Computer Communications*, vol. 153, pp. 11–25, 2020.
- [226] Y. Liu, J. Wang, J. Li, S. Niu, and H. Song, “Machine learning for the detection and identification of internet of things (IoT) devices: A survey,” *arXiv preprint arXiv:2101.10181*, 2021.
- [227] E. Chai, K. Sundaresan, M. A. Khojastepour, and R. Sampath, “LTE in Unlicensed Spectrum: Are We There Yet?” In *22nd ACM International Conference on Mobile Computing and Networking (MobiCom 2016)*, New York City, NY: ACM, Oct. 2016, pp. 135–148.

- [228] F. M. Abinader, E. P. L. Almeida, F. S. Chaves, A. M. Cavalcante, R. D. Vieira, R. C. D. Paiva, A. M. Sobrinho, S. Choudhury, E. Tuomaala, K. Doppler, and V. A. Sousa, "Enabling the Coexistence of LTE and Wi-Fi in Unlicensed Bands," *IEEE Communications Magazine*, vol. 52, pp. 54–61, 2014.
- [229] S. Zinno, G. D. Stasi, S. Avallone, and G. Ventre, "On a fair coexistence of LTE and Wi-Fi in the unlicensed spectrum: A Survey," *Elsevier Computer Communications*, vol. 115, pp. 35–50, 2018.
- [230] I. Tinnirello, P. Gallo, S. Szott, and K. Kosek-Szott, "Impact of LTE's Periodic Interference on Heterogeneous Wi-Fi Transmissions," *IEEE Communications Letters*, vol. 23, no. 2, pp. 342–345, 2018.
- [231] Y. Huang, Y. Chen, Y. T. Hou, W. Lou, and J. H. Reed, "Recent advances of LTE/WiFi coexistence in unlicensed spectrum," *IEEE Network*, vol. 32, no. 2, pp. 107–113, 2017.
- [232] R. Yin, G. Yu, A. Maaref, and G. Y. Li, "LBT-based adaptive channel access for LTE-U systems," *IEEE Transactions on Wireless Communications*, vol. 15, no. 10, pp. 6585–6597, 2016.
- [233] G. Bianchi, "Performance Analysis of the IEEE 802.11 Distributed Coordination Function," *IEEE Journal on Selected Areas in Communications (JSAC)*, vol. 18, no. 3, pp. 535–547, Mar. 2000.
- [234] Y. Gao, L. Cheng, L. Sang, D. Yang, et al., "Spectrum sharing for LTE and Wi-Fi coexistence using decision tree and game theory," in *2016 IEEE Wireless Communications and Networking Conference*, IEEE, 2016, pp. 1–6.
- [235] K. Kosek-Szott, A. Lo Valvo, S. Szott, P. Gallo, and I. Tinnirello, "Downlink channel access performance of NR-U: Impact of numerology and mini-slots on coexistence with Wi-Fi in the 5 GHz band," *Computer Networks*, vol. 195, p. 108 188, 2021.
- [236] I. Tinnirello, A. Lo Valvo, S. Szott, and K. Kosek-Szott, "No Reservations Required: Achieving Fairness between Wi-Fi and NR-U with Self-Deferral Only," in *ACM International Conference on Modelling, Analysis and Simulation of Wireless and Mobile Systems (MSWiM 2021)*, to appear, ACM, 2021.
- [237] X. Wu, M. D. Soltani, L. Zhou, M. Safari, and H. Haas, "Hybrid LiFi and WiFi Networks: A Survey," *IEEE Communications Surveys & Tutorials*, vol. 23, no. 2, pp. 1398–1420, 2021.
- [238] A. M. Alenezi and K. A. Hamdi, "Reinforcement Learning Approach for Hybrid WiFi-VLC Networks," in *2020 IEEE 91st Vehicular Technology Conference (VTC2020-Spring)*, IEEE, 2020, pp. 1–5.
- [239] A. Myles, "LBT should remain the basis of fair and efficient coexistence in 6 GHz unlicensed spectrum," in *doc.: IEEE 802.11-17/0291r0*, IEEE, 2019.
- [240] V. Sathya, S. M. Kala, M. I. Rochman, M. Ghosh, and S. Roy, "Standardization advances for cellular and Wi-Fi coexistence in the unlicensed 5 and 6 GHz bands," *GetMobile: Mobile Computing and Communications*, vol. 24, no. 1, pp. 5–15, 2020.
- [241] M. Hirzallah, Y. Xiao, and M. Krunz, "Matchmaker: An inter-operator network sharing framework in unlicensed bands," in *2019 16th Annual IEEE International Conference on Sensing, Communication, and Networking (SECON)*, IEEE, 2019, pp. 1–9.
- [242] S. Rezwan and W. Choi, "A Survey on Applications of Reinforcement Learning in Flying Ad-Hoc Networks," *Electronics*, vol. 10, no. 4, 2021.
- [243] H. A. A. Al-Rawi, M. A. Ng, and K.-L. A. Yau, "Application of reinforcement learning to routing in distributed wireless networks: a review," *Artificial Intelligence Review*, vol. 43, no. 3, pp. 381–416, Mar. 2015.
- [244] A. McAuley, K. Sinkar, L. Kant, C. Graff, and M. Patel, "Tuning of reinforcement learning parameters applied to OLSR using a cognitive network design tool," in *2012 IEEE Wireless Communications and Networking Conference (WCNC)*, 2012, pp. 2786–2791.
- [245] J.-F. Wagen, V. Adalid, and Y. Maret, "Comparing OLSRd, d2 and -Q Using an Emulated 802.11 or TDMA MANET in a 2-ring Topology," in *2020 International Symposium on Networks, Computers and Communications (ISNCC)*, 2020, pp. 1–5.
- [246] A. Serhani, N. Naja, and A. Jamali, "AQ-Routing: mobility-, stability-aware adaptive routing protocol for data routing in MANET-IoT systems," *Cluster Computing*, vol. 23, no. 1, pp. 13–27, Mar. 2020.
- [247] V. G. Rolla and M. Curado, "A reinforcement learning-based routing for delay tolerant networks," *Engineering Applications of Artificial Intelligence*, vol. 26, no. 10, pp. 2243–2250, 2013.
- [248] K.-E. Lee, J. G. Park, and S.-J. Yoo, "Intelligent Cognitive Radio Ad-Hoc Network: Planning, Learning and Dynamic Configuration," *Electronics*, vol. 10, no. 3, 2021.
- [249] H. Zhang and L. Dai, "Mobility Prediction: A Survey on State-of-the-Art Schemes and Future Applications," *IEEE Access*, vol. 7, pp. 802–822, 2019.
- [250] L. Ghouti, T. R. Sheltami, and K. S. Alutaibi, "Mobility Prediction in Mobile Ad Hoc Networks Using Extreme Learning Machines," *Procedia Computer Science*, vol. 19, pp. 305–312, 2013, The 4th International Conference on Ambient Systems, Networks and Technologies (ANT 2013), the 3rd International Conference on Sustainable Energy Information Technology (SEIT-2013).
- [251] Y. Yayeh, H.-p. Lin, G. Berie, A. B. Agede, L. Yen, and S.-S. Jeng, "Mobility prediction in mobile ad-hoc network using deep learning," in *2018 IEEE International Conference on Applied System Invention (ICASI)*, 2018, pp. 1203–1206.
- [252] E. Mete and T. Girici, "Q-Learning Based Scheduling With Successive Interference Cancellation," *IEEE Access*, vol. 8, pp. 172 034–172 042, 2020.
- [253] S. Karunaratne and H. Gacanin, "An Overview of Machine Learning Approaches in Wireless Mesh Networks," *IEEE Communications Magazine*, vol. 57, no. 4, pp. 102–108, 2019.
- [254] D. Niyato and E. Hossain, "Cognitive radio for next-generation wireless networks: an approach to opportunistic channel selection in IEEE 802.11-based wireless mesh," *IEEE Wireless Communications*, vol. 16, no. 1, pp. 46–54, 2009.
- [255] D. Oriol, T. M. T. Nguyen, and G. Pujolle, "Available bandwidth estimation in Wireless Mesh Networks using neural networks," in *2012 Third International Conference on The Network of the Future (NOF)*, 2012, pp. 1–5.
- [256] M. L. Bote-Lorenzo, E. Gómez-Sánchez, C. Mediavilla-Pastor, and J. I. Asensio-Pérez, "Online machine learning algorithms to predict link quality in community wireless mesh networks," *Computer Networks*, vol. 132, pp. 68–80, 2018.
- [257] A. Al-Saadi, R. Setchi, Y. Hicks, and S. M. Allen, "Routing Protocol for Heterogeneous Wireless Mesh Networks," *IEEE Transactions on Vehicular Technology*, vol. 65, no. 12, pp. 9773–9786, 2016.
- [258] E. Testi, E. Favarelli, L. Pucci, and A. Giorgetti, "Machine Learning for Wireless Network Topology Inference," in *2019 13th International Conference on Signal Processing and Communication Systems (ICSPCS)*, 2019, pp. 1–7.
- [259] L. Cui, S. Yang, F. Chen, Z. Ming, N. Lu, and J. Qin, "A survey on application of machine learning for Internet of Things," *International Journal of Machine Learning and Cybernetics*, vol. 9, no. 8, pp. 1399–1417, Aug. 2018.
- [260] J. Jagannath, N. Polosky, A. Jagannath, F. Restuccia, and T. Melodia, "Machine learning for wireless communications in the Internet of Things: A comprehensive survey," *Ad Hoc Networks*, vol. 93, p. 101 913, 2019.
- [261] F. Hussain, S. A. Hassan, R. Hussain, and E. Hossain, "Machine Learning for Resource Management in Cellular and IoT Networks: Potentials, Current Solutions, and Open Challenges," *IEEE Communications Surveys & Tutorials*, vol. 22, no. 2, pp. 1251–1275, 2020.
- [262] L. Lei, Y. Tan, K. Zheng, S. Liu, K. Zhang, and X. Shen, "Deep Reinforcement Learning for Autonomous Internet of Things: Model, Applications and Challenges," *IEEE Communications Surveys & Tutorials*, vol. 22, no. 3, pp. 1722–1760, 2020.
- [263] S. K. Sharma and X. Wang, "Toward Massive Machine Type Communications in Ultra-Dense Cellular IoT Networks: Current Issues and Machine Learning-Assisted Solutions," *IEEE Communications Surveys & Tutorials*, vol. 22, no. 1, pp. 426–471, 2020.
- [264] M. Kulin, T. Kazaz, I. Moerman, and E. De Poorter, "End-to-End Learning From Spectrum Data: A Deep Learning Approach for Wireless Signal Identification in Spectrum Monitoring Applications," *IEEE Access*, vol. 6, pp. 18 484–18 501, 2018.
- [265] M. Schmidt, D. Block, and U. Meier, "Wireless interference identification with convolutional neural networks," in *2017 IEEE 15th International Conference on Industrial Informatics (INDIN)*, 2017, pp. 180–185.
- [266] S. Grimaldi, A. Mahmood, and M. Gidlund, "An SVM-Based Method for Classification of External Interference in Industrial Wireless Sensor and Actuator Networks," *Journal of Sensor and Actuator Networks*, vol. 6, no. 2, 2017.
- [267] —, "Real-Time Interference Identification via Supervised Learning: Embedding Coexistence Awareness in IoT Devices," *IEEE Access*, vol. 7, pp. 835–850, 2019.
- [268] W. Xu, C. Ma, S. Guo, and H. Zhou, "Efficient Rate Adaptation for 802.11af TVWS Vehicular Access via Deep Learning," in *2019 IEEE Global Communications Conference (GLOBECOM)*, 2019, pp. 1–6.
- [269] W. Xu, H. Zhou, N. Cheng, N. Lu, L. Xu, M. Qin, and S. Guo, "Autonomous Rate Control for Mobile Internet of Things: A Deep Reinforcement Learning Approach," in *2020 IEEE 92nd Vehicular Technology Conference (VTC2020-Fall)*, 2020, pp. 1–6.

- [270] L. Tian, S. Santi, A. Seferagić, J. Lan, and J. Famaey, “Wi-Fi HaLow for the Internet of Things: An up-to-date survey on IEEE 802.11ah research,” *Journal of Network and Computer Applications*, vol. 182, p. 103036, 2021.
- [271] L. Tian, M. Mehari, S. Santi, S. Latré, E. De Poorter, and J. Famaey, “IEEE 802.11ah Restricted Access Window Surrogate Model for Real-Time Station Grouping,” in *2018 IEEE 19th International Symposium on “A World of Wireless, Mobile and Multimedia Networks” (WoWMoM)*, 2018, pp. 14–22.
- [272] L. Tian, E. Lopez-Aguilera, E. Garcia-Villegas, M. T. Mehari, E. De Poorter, S. Latré, and J. Famaey, “Optimization-Oriented RAW Modeling of IEEE 802.11ah Heterogeneous Networks,” *IEEE Internet of Things Journal*, vol. 6, no. 6, pp. 10597–10609, 2019.
- [273] M. Mahesh and V. P. Harigovindan, “ANN-based optimization framework for performance enhancement of Restricted Access Window mechanism in dense IoT networks,” *Sādhanā*, vol. 45, no. 1, p. 52, Feb. 2020.
- [274] Y. Liu, J. Guo, P. Orlik, Y. Nagai, K. Watanabe, and T. Sumi, “Coexistence of 802.11ah and 802.15.4g networks,” in *2018 IEEE Wireless Communications and Networking Conference (WCNC)*, 2018, pp. 1–6.
- [275] T.-C. Chang, C.-H. Lin, K. C.-J. Lin, and W.-T. Chen, “Traffic-Aware Sensor Grouping for IEEE 802.11ah Networks: Regression Based Analysis and Design,” *IEEE Transactions on Mobile Computing*, vol. 18, no. 3, pp. 674–687, 2019.
- [276] M. Mahesh, B. S. Pavan, and V. Harigovindan, “Data rate-based grouping using machine learning to improve the aggregate throughput of IEEE 802.11ah multi-rate IoT networks,” in *2020 IEEE International Conference on Advanced Networks and Telecommunications Systems (ANTS)*, 2020, pp. 1–5.
- [277] V. Ninkovic, A. Valka, D. Dumić, and D. Vukobratovic, “Deep learning based packet detection and carrier frequency offset estimation in IEEE 802.11ah,” *arXiv preprint arXiv:2004.11716*, 2020.
- [278] Y. Zhao, J. Hu, K. Yang, and S. Cui, “Deep Reinforcement Learning Aided Intelligent Access Control in Energy Harvesting Based WLAN,” *IEEE Transactions on Vehicular Technology*, vol. 69, no. 11, pp. 14078–14082, 2020.
- [279] C. Chen, J. Li, V. Balasubramaniam, Y. Wu, Y. Zhang, and S. Wan, “Contention Resolution in Wi-Fi 6-Enabled Internet of Things Based on Deep Learning,” *IEEE Internet of Things Journal*, vol. 8, no. 7, pp. 5309–5320, 2021.
- [280] K.-S. Shin, G.-H. Hwang, and O. Jo, “Distributed reinforcement learning scheme for environmentally adaptive IoT network selection,” *Electronics Letters*, vol. 56, no. 9, pp. 462–464, 2020.
- [281] K. Li, W. Ni, and F. Dressler, “Continuous Maneuver Control and Data Capture Scheduling of Autonomous Drone in Wireless Sensor Networks,” *IEEE Transactions on Mobile Computing*, Jan. 2021, to appear.
- [282] H. Kurunathan, K. Li, W. Ni, E. Tovar, and F. Dressler, “Deep Reinforcement Learning for Persistent Cruise Control in UAV-aided Data Collection,” in *46th IEEE Conference on Local Computer Networks (LCN 2021)*, to appear, Virtual Conference: IEEE, Oct. 2021.
- [283] H. Ye, L. Liang, G. Ye Li, J. Kim, L. Lu, and M. Wu, “Machine Learning for Vehicular Networks: Recent Advances and Application Examples,” *IEEE Vehicular Technology Magazine*, vol. 13, no. 2, pp. 94–101, 2018.
- [284] L. Liang, H. Ye, and G. Y. Li, “Toward Intelligent Vehicular Networks: A Machine Learning Framework,” *IEEE Internet of Things Journal*, vol. 6, no. 1, pp. 124–135, 2019.
- [285] W. Tong, A. Hussain, W. X. Bo, and S. Maharjan, “Artificial Intelligence for Vehicle-to-Everything: A Survey,” *IEEE Access*, vol. 7, pp. 10823–10843, 2019.
- [286] W. Xu, H. Zhou, H. Wu, F. Lyu, N. Cheng, and X. Shen, “Intelligent Link Adaptation in 802.11 Vehicular Networks: Challenges and Solutions,” *IEEE Communications Standards Magazine*, vol. 3, no. 1, pp. 12–18, 2019.
- [287] M. Noor-A-Rahim, Z. Liu, H. Lee, G. G. M. N. Ali, D. Pesch, and P. Xiao, “A Survey on Resource Allocation in Vehicular Networks,” *IEEE Transactions on Intelligent Transportation Systems*, pp. 1–21, 2020.
- [288] J. Posner, L. Tseng, M. Aloqaily, and Y. Jararweh, “Federated Learning in Vehicular Networks: Opportunities and Solutions,” *IEEE Network*, vol. 35, no. 2, pp. 152–159, 2021.
- [289] A. Memedi and F. Dressler, “Vehicular Visible Light Communications: A Survey,” *IEEE Communications Surveys & Tutorials*, vol. 23, no. 1, pp. 161–181, Jan. 2021.
- [290] M. A. Hossain, R. M. Noor, K.-L. A. Yau, S. R. Azzuhri, M. R. Z’aba, and I. Ahmedy, “Comprehensive Survey of Machine Learning Approaches in Cognitive Radio-Based Vehicular Ad Hoc Networks,” *IEEE Access*, vol. 8, pp. 78054–78108, 2020.
- [291] A. Bazzi, B. M. Masini, A. Zanella, and I. Thibault, “On the Performance of IEEE 802.11p and LTE-V2V for the Cooperative Awareness of Connected Vehicles,” *IEEE Transactions on Vehicular Technology*, vol. 66, no. 11, pp. 10419–10432, Nov. 2017.
- [292] H. Ye and G. Y. Li, “Deep Reinforcement Learning for Resource Allocation in V2V Communications,” in *2018 IEEE International Conference on Communications (ICC)*, 2018, pp. 1–6.
- [293] A. Pressas, Z. Sheng, F. H. Ali, D. Tian, and M. Nekovee, “Contention-based Learning MAC Protocol for Broadcast Vehicle-to-Vehicle Communication,” in *9th IEEE Vehicular Networking Conference (VNC 2017)*, Turin, Italy: IEEE, Nov. 2017.
- [294] A. Pressas, Z. Sheng, F. Ali, and D. Tian, “A Q-Learning Approach With Collective Contention Estimation for Bandwidth-Efficient and Fair Access Control in IEEE 802.11p Vehicular Networks,” *IEEE Transactions on Vehicular Technology*, vol. 68, no. 9, pp. 9136–9150, 2019.
- [295] S. Kim and B.-J. Kim, “Reinforcement Learning for Accident Risk-Adaptive V2X Networking,” in *2020 IEEE 92nd Vehicular Technology Conference (VTC2020-Fall)*, 2020, pp. 1–7.
- [296] Y. Xu, L. Li, B.-H. Soong, and C. Li, “Fuzzy Q-learning based vertical handoff control for vehicular heterogeneous wireless network,” in *2014 IEEE International Conference on Communications (ICC)*, 2014, pp. 5653–5658.
- [297] S. R. Pokhrel and J. Choi, “Improving TCP Performance Over WiFi for Internet of Vehicles: A Federated Learning Approach,” *IEEE Transactions on Vehicular Technology*, vol. 69, no. 6, pp. 6798–6802, 2020.
- [298] J. Pan, H. Shan, R. Li, Y. Wu, W. Wu, and T. Q. Quek, “Channel Estimation Based on Deep Learning in Vehicle-to-Everything Environments,” *IEEE Communications Letters*, vol. 25, no. 6, pp. 1891–1895, 2021.
- [299] W. Xu, S. Guo, S. Ma, H. Zhou, M. Wu, and W. Zhuang, “Augmenting Drive-Thru Internet via Reinforcement Learning-Based Rate Adaptation,” *IEEE Internet of Things Journal*, vol. 7, no. 4, pp. 3114–3123, 2020.
- [300] G. Naik, B. Choudhury, and J.-M. Park, “IEEE 802.11bd & 5G NR V2X: Evolution of Radio Access Technologies for V2X Communications,” *IEEE Access*, 2019.
- [301] V. Va, T. Shimizu, G. Bansal, and R. W. Heath, “Position-aided millimeter wave V2I beam alignment: A learning-to-rank approach,” in *2017 IEEE 28th Annual International Symposium on Personal, Indoor, and Mobile Radio Communications (PIMRC)*, 2017, pp. 1–5.
- [302] Y. Wang, A. Klautau, M. Ribero, M. Narasimha, and R. W. Heath, “MmWave Vehicular Beam Training with Situational Awareness by Machine Learning,” in *2018 IEEE Globecom Workshops (GC Wkshps)*, 2018, pp. 1–6.
- [303] Y. Wang, A. Klautau, M. Ribero, A. C. K. Soong, and R. W. Heath, “MmWave Vehicular Beam Selection With Situational Awareness Using Machine Learning,” *IEEE Access*, vol. 7, pp. 87479–87493, 2019.
- [304] Y. Wang, M. Narasimha, and R. W. Heath, “MmWave Beam Prediction with Situational Awareness: A Machine Learning Approach,” in *2018 IEEE 19th International Workshop on Signal Processing Advances in Wireless Communications (SPAWC)*, 2018, pp. 1–5.
- [305] Y. Wang, M. Narasimha, and R. W. Heath, “Towards Robustness: Machine Learning for MmWave V2X with Situational Awareness,” in *2018 52nd Asilomar Conference on Signals, Systems, and Computers*, 2018, pp. 1577–1581.
- [306] R. Sadeghi, J. P. Barraca, and R. L. Aguiar, “A Survey on Cooperative MAC Protocols in IEEE 802.11 Wireless Networks,” *Wireless Personal Communications*, vol. 95, no. 2, pp. 1469–1493, Jul. 2017.
- [307] Z. HU and C.-K. THAM, “CCMAC: Coordinated cooperative MAC for wireless LANs,” *Computer networks (1999)*, vol. 54, no. 4, pp. 618–630, 2010.
- [308] A. Abdelreheem, O. A. Omer, H. Esmail, and U. S. Mohamed, “Deep Learning-Based Relay Selection In D2D Millimeter Wave Communications,” in *2019 International Conference on Computer and Information Sciences (ICCIS)*, 2019, pp. 1–5.
- [309] I. Lahsen-Cherif, L. Zitoun, and V. Vèque, “Energy Efficient Routing for Wireless Mesh Networks with Directional Antennas: When Q-learning meets Ant systems,” *Ad Hoc Networks*, vol. 121, p. 102589, 2021.

- [310] T. Zugno, M. Drago, M. Giordani, M. Polese, and M. Zorzi, "Toward Standardization of Millimeter-Wave Vehicle-to-Vehicle Networks: Open Challenges and Performance Evaluation," *IEEE Communications Magazine*, vol. 58, no. 9, pp. 79–85, 2020.
- [311] M. E. Morocho-Cayamcela, H. Lee, and W. Lim, "Machine Learning to Improve Multi-Hop Searching and Extended Wireless Reachability in V2X," *IEEE Communications Letters*, vol. 24, no. 7, pp. 1477–1481, 2020.
- [312] F. Wilhelmi, M. Carrascosa, C. Cano, A. Jonsson, V. Ram, and B. Bellalta, "Usage of network simulators in machine-learning-assisted 5G/6G networks," *IEEE Wireless Communications*, vol. 28, no. 1, pp. 160–166, 2021.
- [313] C. Sommer, R. German, and F. Dressler, "Bidirectionally Coupled Network and Road Traffic Simulation for Improved IVC Analysis," *IEEE Transactions on Mobile Computing*, vol. 10, no. 1, pp. 3–15, Jan. 2011.
- [314] M. Schettler, D. S. Buse, A. Zubow, and F. Dressler, "How to Train your ITS? Integrating Machine Learning with Vehicular Network Simulation," in *12th IEEE Vehicular Networking Conference (VNC 2020)*, Virtual Conference: IEEE, Dec. 2020.
- [315] H. Yin, P. Liu, K. Liu, L. Cao, L. Zhang, Y. Gao, and X. Hei, "ns3-ai: Fostering Artificial Intelligence Algorithms for Networking Research," in *Proceedings of the 2020 Workshop on ns-3*, 2020, pp. 57–64.
- [316] A. Zubow, S. Rösler, P. Gawłowicz, and F. Dressler, "GrGym: When GNU Radio goes to (AI) Gym," in *22nd ACM International Workshop on Mobile Computing Systems and Applications (HotMobile 2021)*, Virtual Conference: ACM, Feb. 2021, pp. 8–14.
- [317] J. Deng, W. Dong, R. Socher, L. Li, K. Li, and L. Fei-Fei, "ImageNet: A large-scale hierarchical image database," in *2009 IEEE Conference on Computer Vision and Pattern Recognition*, Miami, FL: IEEE, Jun. 2009, pp. 248–255.
- [318] A. U. Chaudhry and H. M. Roshdy Hafez, "On Finding Hidden Relationship among Variables in WiFi using Machine Learning," in *2020 International Conference on Computing, Networking and Communications (ICNC)*, 2020, pp. 157–161.
- [319] A. Chakraborty, S. Sanadhya, S. R. Das, D. Kim, and K.-H. Kim, "ExBox: Experience Management Middlebox for Wireless Networks," in *12th ACM International Conference on Emerging Networking Experiments and Technologies (CoNEXT 2016)*, Irvine, CA: ACM, Dec. 2016, pp. 145–159.
- [320] H. Fulara, G. Singh, D. Jaisinghani, M. Maity, T. Chakraborty, and V. Naik, "Use of Machine Learning to Detect Causes of Unnecessary Active Scanning in WiFi Networks," in *20th IEEE International Symposium on a World of Wireless, Mobile and Multimedia Networks (WoWMoM 2019)*, Washington, D.C.: IEEE, Jun. 2019, pp. 1–9.
- [321] H. B. Pasandi and T. Nadeem, "Towards A Learning-Based Framework for Self-Driving Design of Networking Protocols," *IEEE Access*, vol. 9, pp. 34 829–34 844, 2021.
- [322] F. Wilhelmi, S. Barrachina-Munoz, B. Bellalta, C. Cano, A. Jonsson, and V. Ram, "A flexible machine-learning-aware architecture for future WLANs," *IEEE Communications Magazine*, vol. 58, no. 3, pp. 25–31, 2020.
- [323] W. Samek and K.-R. Müller, "Towards Explainable Artificial Intelligence," in *Explainable AI: Interpreting, Explaining and Visualizing Deep Learning*, W. Samek, G. Montavon, A. Vedaldi, L. K. Hansen, and K.-R. Müller, Eds. Cham: Springer International Publishing, 2019.
- [324] F. Malandrino and C. F. Chiasserini, "Federated Learning at the Network Edge: When Not All Nodes Are Created Equal," *IEEE Communications Magazine*, vol. 59, no. 7, pp. 68–73, Jul. 2021.
- [325] E. S. Olivas, J. D. M. Guerrero, M. M. Sober, J. R. M. Benedito, and A. J. S. Lopez, *Handbook Of Research On Machine Learning Applications and Trends: Algorithms, Methods and Techniques*. Hershey, PA: Information Science Reference, 2009.

CONTENTS

I	Introduction	1	IX	Future Research Directions	32
II	Related surveys	3	IX-A	Dealing with New and Flexible but Complex WiFi Features	32
II-A	WiFi-related Surveys	4	IX-B	Joint Optimization of WiFi Features . .	32
II-B	Wireless Communications-related Surveys	4	IX-C	ML-enhanced WiFi Features by Design	33
II-C	WiFi and 5G/6G-related Surveys	4	IX-D	ML-based Architectures and Standard- ized Interfaces	33
II-D	Summary	4	IX-E	Set of Reference Evaluation Scenarios and Performance Metrics	33
III	Core WiFi Features	5	IX-F	ML-enhanced Network Simulation Tools	33
III-A	Channel Access	5	IX-G	Testbeds and Real Pilots	33
III-B	Link Configuration	8	IX-H	Risks of ML Uncertainty	33
III-B1	Rate Adaptation	8	IX-I	New ML Models and Distributed Learning	34
III-B2	SIG Adaptation	9	X	Conclusion	34
III-B3	PHY Layer Trade-offs	9	Appendix A: List of Acronyms		34
III-C	Frame Aggregation	10			
III-D	Traffic Prediction	11			
III-E	PHY Features	12			
III-F	Open Challenges	13			
IV	Recent WiFi Features	13			
IV-A	Beamforming	13			
IV-B	Multi-user Communication	15			
IV-C	Spatial Reuse	16			
IV-D	Channel Bonding	17			
IV-E	Multi-band, Network MIMO, and Full- duplex	18			
IV-F	Open Challenges	19			
V	WiFi Management	20			
V-A	Channel and Band Selection	20			
V-B	AP Selection and Association	21			
V-C	Management Architectures	22			
V-D	Predicting the Health of WiFi Connections	23			
V-E	Open Challenges	23			
VI	Coexistence Scenarios	24			
VI-A	Fair Channel Sharing with Cellular Net- works	24			
VI-B	Network Monitoring	27			
VI-C	Signal Classification	27			
VI-D	Cooperative Coexistence	28			
VI-E	Open Challenges	28			
VII	Multihop Wi-Fi Networks	28			
VII-A	Ad Hoc Networks	28			
VII-B	Mesh Networks	29			
VII-C	Sensor Networks	29			
VII-D	Vehicular Networks	30			
VII-E	Relay Networks	30			
VII-F	Open Challenges	30			
VIII	Available Tools and Datasets	31			
VIII-A	Tool Chains	31			
VIII-B	Datasets	31			